

Universal Off-line LED Driver Demoboard

Introduction

The Supertex HV9921DB1 demoboard is a complete LED power driver to supply a string of LEDs using the HV9921, an integrated 3-pin high input voltage constant-current buck regulator IC. The HV9921 integrates a 500V switching MOSFET and can operate directly from the rectified universal AC line voltage range of 80 to 265VAC.

The current in the LED string is internally programmed to 20mA ±15%. The HV9921DB1 is ideally suited for driving strings of LEDs having forward voltage from 20 to 50V at high efficiency (typically 80% at 120VAC).

The HV9921DB1 is a peak current-controlled buck converter operating with fixed off-time of 10.5us. Its fixed off-time control scheme provides good stability and tight regulation of the LED current throughout the input AC line voltage range. As its switching frequency varies over the AC line cycle, the HV9921 inherently introduces frequency dither and simplifies the compliance with EMI regulations.

Specifications

Parameter	Value
Input voltage range	80 to 265VAC
Load current	20mA ± 15%
LED string voltage	20 ~ 50V
Conducted EMI	CISPR15
Efficiency	80% typ.

Board Layout and Connection Diagram

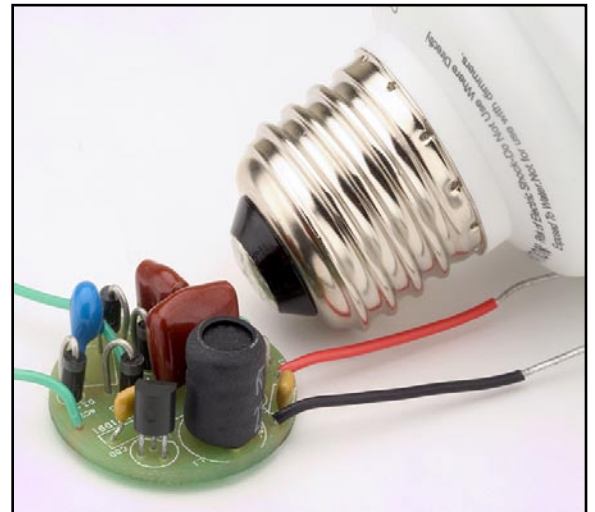
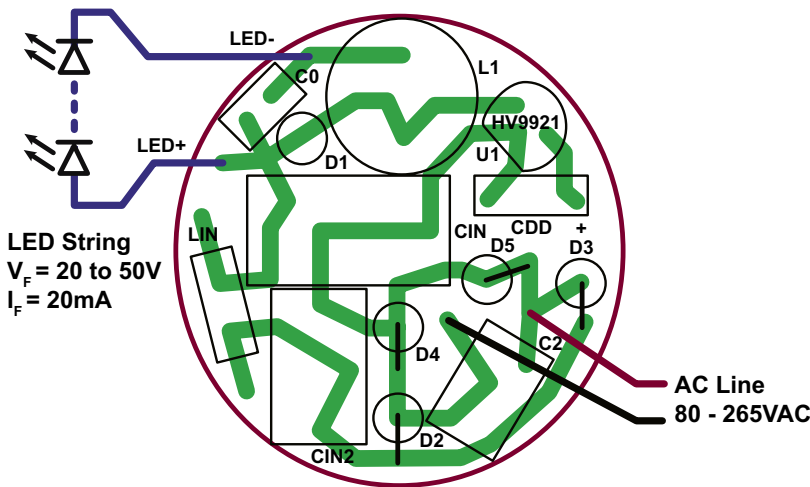

Connections

LED+: Connect the Anode of the LED string to this pin.

LED-: Connect the Cathode of the LED string to this pin.

AC1, AC2: Connect AC Line to these pins.

Note:

The demoboard is not protected from output open/short circuit condition. Damage to the demoboard may occur if the output load is not properly connected.

Testing the HV9921DB1

Connect the LED string to the output terminals.

Check the polarity of the LED connection, anode end of the string should be connected to the positive output, cathode should be connected to the negative output. Connect the AC input to the input terminals. Apply the AC voltage at the input terminals and the LED string should start to glow. The HV9921DB1 will regulate constant 20mA current in the LED.

An ammeter can be connected in series with the LED(s) to measure the output current. The average current reading may be smaller than 20mA. This is due to the interruptions in the LED current when the input AC line voltage falls below the forward voltage of the LED string. The average current will also vary over the AC line voltage range. Additional hold-up capacitance can be included across C_{IN} , if these interruptions are not desirable.

Schematic Diagram

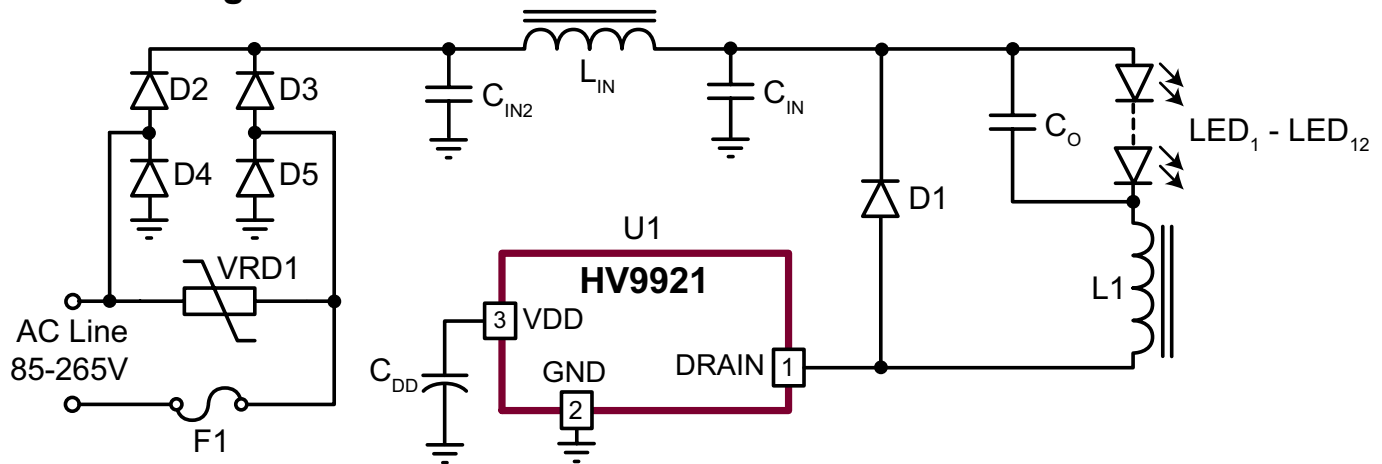

Bill of Materials

Reference	Description	Part Number	Manufacturer
C_{IN}	0.1 μ F, 400V, metalized polyester film	ECQ-E4104KF	Panasonic
C_{IN2}	0.033 μ F, 400V, metalized polyester film	ECQ-E4333KF	Panasonic
C_O	0.01 μ F, 100V, X7R, MLCC	B37981M1103K054	Epcos
C_{DD}	0.1 μ F, 50V, X7R, MLCC	B37987F5104K054	Epcos
L1	68mH, 36mA, mini-drum	RL-5480-3-68000	Renco Electronics
L_{IN}	2.2mH, 64mA, axial	CTH6-222K	Central Technologies
D1	Diode, UF 600V 1.0A 75ns	MUR160	On Semiconductor
D2-5	Diode, 600V 1.0A	1N4005	Diodes, Inc
VRD1	Surge absorber	ERZ-V05D431	Panasonic
U1	LED Driver IC	HV9921N3-G	Supertex, Inc
F1	Integrated PCB fuse	N/A	N/A

Supertex inc. does not recommend the use of its products in life support applications, and will not knowingly sell them for use in such applications unless it receives an adequate "product liability indemnification insurance agreement." **Supertex inc.** does not assume responsibility for use of devices described, and limits its liability to the replacement of the devices determined defective due to workmanship. No responsibility is assumed for possible omissions and inaccuracies. Circuitry and specifications are subject to change without notice. For the latest product specifications refer to the **Supertex inc.** (website: <http://www.supertex.com>)