

**Product
Summary
Sheet**

**Hysteretic, Buck, High Brightness LED Driver
with High-Side Current Sensing**

Applications:

- ▶ Low voltage industrial and architectural LED lighting
- ▶ General purpose constant current source
- ▶ Signage and decorative LED lighting
- ▶ Indicator and emergency lighting

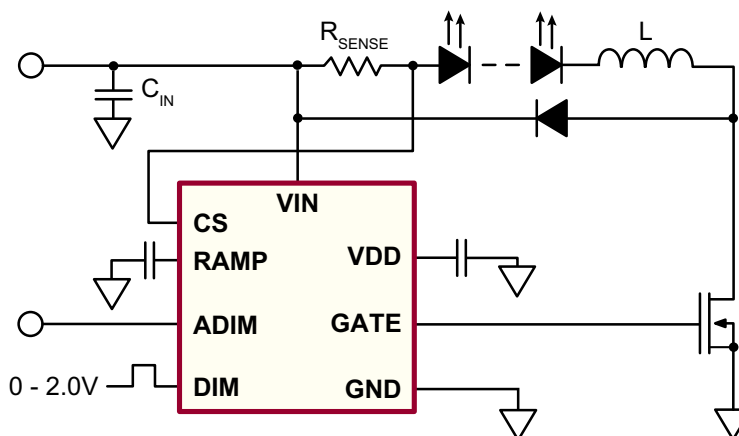

Typical Application Circuit

Product Overview:

The HV9919 is a PWM controller IC designed to drive high brightness LEDs using a buck topology. It operates from an input voltage of 4.5 to 40VDC and employs hysteretic control with a high-side current sense resistor to set the constant output current.

The operating frequency range can be set by selecting the proper inductor. Operation at high switching frequency is possible since the hysteretic control maintains accuracy even at high frequencies. This permits the use of small inductors and capacitors minimizing space and cost in the overall system.

LED brightness control is achieved with PWM dimming from an analog or PWM input signal. Unique PWM circuitry allows true constant color with a high dimming range. The dimming frequency is programmed using a single external capacitor.

The HV9919 comes in a small, 8-lead DFN package and is ideal for industrial and general lighting applications.

Features:	Benefits:
Hysteretic control with high-side current sensing	Current sense resistor sets constant output current
Up to 2.0MHz switching frequency	Small inductors and capacitors may be used in the circuit design, thus reducing system size and cost
Analog or PWM control signal for PWM dimming	Provides a high dimming range and true constant color
Over-temperature protection and wide operating temperature range (-40°C to +125°C)	Protected against damage in extreme temperature conditions



8-Lead DFN (K7)



Hysteretic, Buck, High Brightness LED Driver with High-Side Current Sensing

Ordering Information / Availability

<u>Part Number</u>	<u>Package Option</u>	<u>Samples</u>	<u>Lead Time</u>
HV9919K7-G	8-Lead DFN	Now	4-6 Weeks ARO

-G indicates the part is RoHS compliant (Green).



Product Contact

For any questions regarding the HV9919 please contact your local area Supertex sales office, or contact the main office in the US at:

Telephone: 800-222-8888
EMail: mktg@supertex.com
Website: www.supertex.com

Supertex inc.

1235 Bordeaux Drive, Sunnyvale, CA 94089