

Product Summary Sheet

Switch-mode LED Driver IC with High Current Accuracy and Hiccup Mode Protection

Applications

- ▶ LED backlight applications
- ▶ General LED lighting applications
- ▶ Battery powered LED lamps

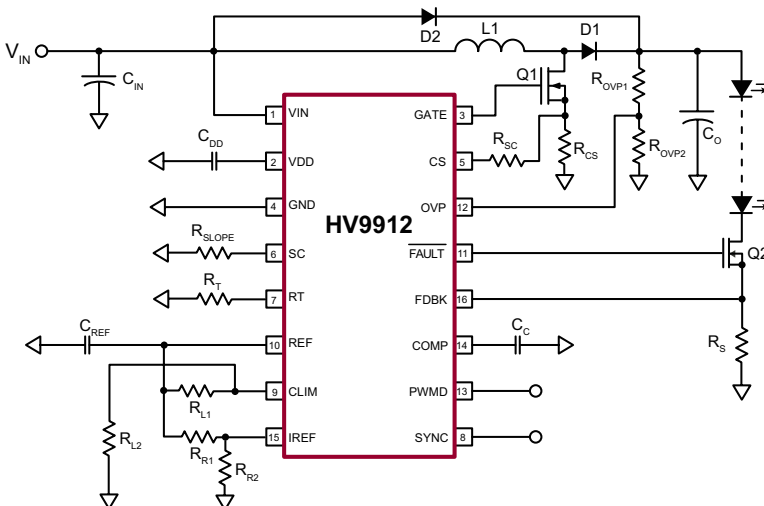

Typical Application Circuit



16-Lead SOIC (NG)

Product Overview:

The HV9912 is a current mode control LED driver IC designed to control single switch PWM converters (buck, boost, buck-boost or SEPIC) in a constant frequency mode. The controller uses a peak current-mode control scheme with programmable slope compensation and includes an internal transconductance amplifier to control the output current in closed loop enabling high output current accuracy (in the case of buck and buck-boost converters, the output current can be sensed using a high side current sensor like the HV7800). In the constant frequency mode, multiple HV9912 ICs can be synchronized to each other or to an external clock using the SYNC pin. Programmable MOSFET current limit enables current limiting during input under voltage and output overload conditions. The IC also includes a 0.2A source and 0.4A sink gate driver that makes the HV9912 suitable for high power applications. An internal 90V linear regulator powers the IC eliminating the need for a separate power supply for the IC. The IC also provides a FAULT output, which can be used to disconnect the LEDs in case of a fault condition using an external disconnect FET. HV9912 also provides a TTL compatible, low-frequency PWM dimming input that can accept an external control signal with a duty ratio of 0-100% and a frequency of up to a few kilohertz. The HV9912 includes hiccup protection from both short and open circuits, with automatic recovery after the fault condition is cleared.

The HV9912 is a pin compatible replacement to Supertex's HV9911. It is compatible with existing HV9911 designs which have an input voltage of less than 90V.

Features:	Benefits:
Internal transconductance Op Amp	Closed loop system. Tighter line and load regulation of the LED current with good transient response to PWM dimming
Synchronization	Prevent sub-harmonic oscillations associated with driving multiple LED drivers - phase control operation with external clock
Hiccup mode protection	Protects the LED driver from being damaged during an over-current/over-voltage fault condition and enables it to restart automatically when the fault is removed.
Programmable internal OVP comparator and short circuit protection	Integrated Open LED and output short circuit protection
Slope compensation	Allows for wider range of operation (larger strings of LED) in fixed frequency mode



Switch-mode LED Driver IC with High Current Accuracy and Hiccup Mode Protection

Ordering Information / Availability

Part Number	Package Option	Engineering Samples	Production Samples	Production Lead Time
HV9912NG-G	16-Lead SOIC (Green)	Now	6 Weeks	8-10 Weeks ARO

-G indicates the part is RoHS compliant (Green).



Product Contact

For any questions regarding the HV9912 please contact your local area Supertex sales office, or contact the main office in the US at:

Telephone: 800-222-8888
 Fax: 408-222-4895
 EMail: mktg@supertex.com
 Website: www.supertex.com

Supertex inc.

1235 Bordeaux Drive, Sunnyvale, CA 94089