

# High Brightness Boost LED Driver Demoboard with 1:3000 Dimming Ratio and Hiccup Mode Protection

## General Description

The HV9912DB1 is an LED driver demoboard capable of driving up to 20 one-watt LEDs in series from an input of 21 - 27VDC. It uses the Supertex HV9912 in a boost topology. The converter has very good initial regulation (+/-5%) and excellent line and load regulation over the entire input and output voltage range (<+/- 1%). The full load efficiency of the converter is typically greater than 90%.

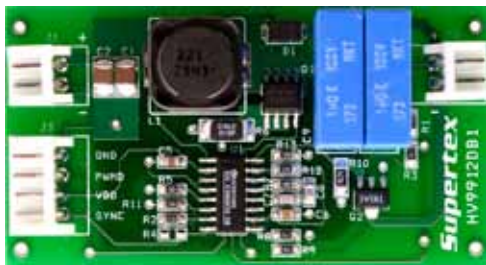
The HV9912DB1 is protected against open LED and output short circuit conditions. It is also protected under input under-voltage conditions by limiting the input current. It has an excellent PWM dimming response, with typical rise and fall times less than 1.0µs, which allows high PWM dimming ratios. The switching frequency of the HV9912DB1 can be synchronized to other HV9912 boards or to an external 200kHz clock by connecting the clock to the SYNC pin of the HV9912DB1.

The HV9912DB1 features hiccup mode short circuit and open LED protection. Upon detection of either fault condition, the IC shuts down the driver and periodically attempts to restart until the fault condition ends. The HV9912DB1 also features a built-in 500ns blanking to prevent false tripping of the over-current comparator due to parasitic capacitance spikes during PWM dimming.

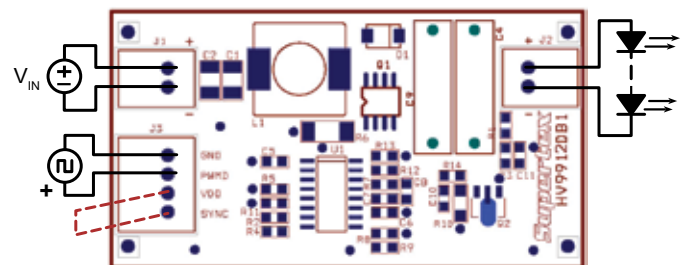
## Specifications

Parameter	Value
Input voltage (steady state):	21 - 27VDC
Output LED string voltage:	35V min - 80V max
Output current:	350mA +/-5%
Output current ripple:	10% typical
Switching frequency:	200kHz
Full load efficiency:	93% (at 24V input)
Open LED protection:	Shuts down at 92V
Output short circuit protection:	Included
Input under voltage protection:	Included
PWM dimming:	1:3000 dimming ratio at 200Hz

## Board Layout and Connection Diagram



Actual size: 64.0mm x 34.5mm



## Connections

**Input** - The input is connected between the terminals of connector J1 as shown in the Connection Diagram.

**Output** - The output is connected between the terminals of connector J2 as shown.

**Enable/PWM Dimming** - To just enable the board, short pins PWM and VDD of connector J3 as shown by the dashed lines. To PWM dim the board, connect the external push-pull waveform source between terminals PWM and GND of connector J3 as shown by the solid lines.

**SYNC** - To synchronize two or more boards, connect the SYNC pins of all the boards together. To synchronize the HV9912DB1 to an external 200kHz clock, connect the clock between the SYNC and GND pins of terminal J3.

**Note:**

*During PWM dimming, pin 2 of connector J3 should be left open. Also, the PWM signal must have the proper polarity with the positive connected to pin 3 of J3. Note that pin 4 of J3 is internally connected to the return path of the input voltage.*

## Testing The Demoboard

**Normal Operation:** Connect the input source and the output LEDs as shown in the Connection Diagram and enable the board. The LEDs will glow with a steady intensity. Connecting an ammeter in series with the LEDs will allow measurement of the LED current. The current will be 350mA +/- 5%.

**Current Regulation:** With the input power to the converter disconnected, change the LED string voltage within the specifications mentioned. The current output of the HV9912DB1 will remain very steady over the entire load range. Vary the input voltage while the circuit is operational. The current will be regulated over the entire line range.

**Open LED test:** Connect a voltmeter across the output terminals of the HV9912DB1. Start the demoboard normally, and once the LED current reaches steady state, unplug one end of the LED string from the demoboard. The output voltage will rise to about 92V and the HV9912DB1 will shut down. Once the LED string is reconnected, the driver will start regulating current.

**Short Circuit Test:** When the HV9912DB1 is operating in steady state, connect a jumper across the terminals of the LED string. Notice that the output current will immediately go to zero and the converter will shut down. Removing the jumper will cause the HV9912DB1 to restart and continue to regulate the LED current.

**PWM Dimming:** With the input voltage to the board disconnected, apply a TTL compatible, push-pull square wave signal between PWMD and GND terminals of connector J3 as shown in the Connection Diagram. Turn the input voltage back on and adjust the duty cycle and/or frequency of the PWM dimming signal. The output current will track the PWM dimming signal. Note that although the converter operates perfectly well at 1.0kHz PWM dimming frequency, the widest PWM dimming ratio can be obtained at lower frequencies like 100 or 200Hz.

## Typical Results

**1. Efficiency:** The efficiency of the converter at various LED string voltages are shown in Fig.1 (measured at the nominal input voltage of 24V). Fig.2 shows the full load efficiency of the converter at varying input voltages. The minimum efficiency of 93% for the converter occurs at 21V input and full load output.

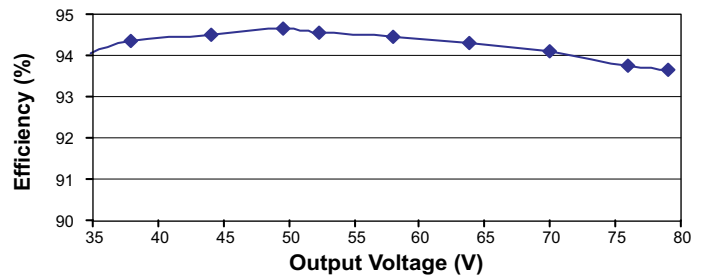


Fig. 1 Efficiency vs. Output Voltage

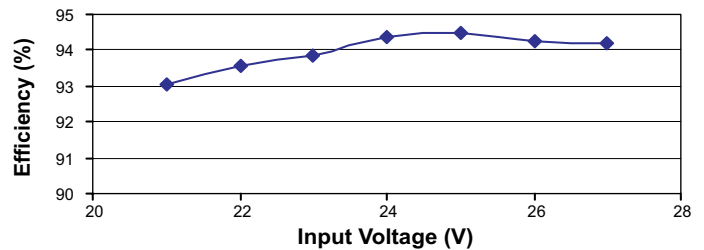


Fig. 2 Efficiency vs. Input Voltage

**2. Current Regulation:** Figs. 3 and 4 show the output current regulation vs. output voltage and input voltage respectively. The total current regulation (line and load combined) is found to be less than 1%.

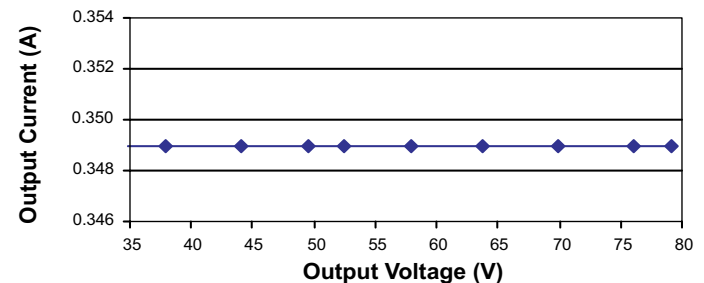


Fig. 3 Output Current vs. Output Voltage

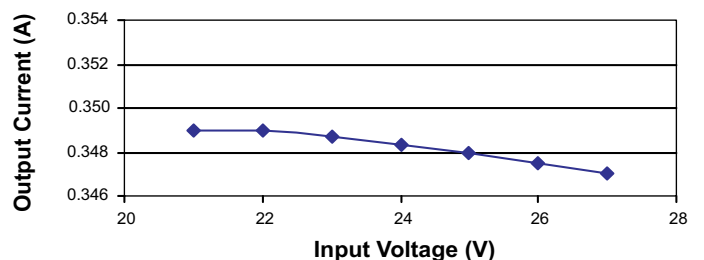
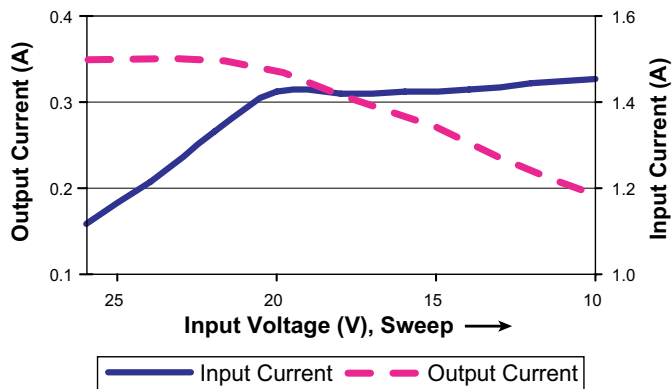


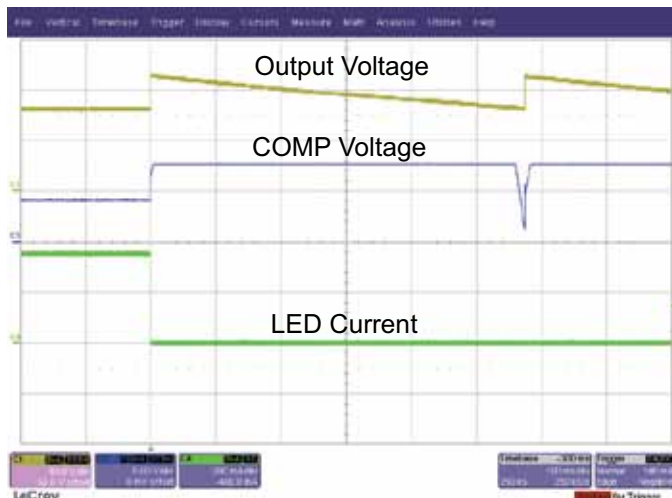
Fig. 4 Output Current vs. Input Voltage

**3. Input Under Voltage Protection:** Input under voltage protection is provided by limiting the input current at low input voltages. Fig. 5 shows the output and input currents at voltages less than the minimum rated voltage. The LED current will decrease as the input voltage falls and the input current limits to about 1.4A. Note that the input current limit is not a hard limit as the slope compensation added to the peak current sense signal will allow a small change in the input current with a decrease in the input voltage.

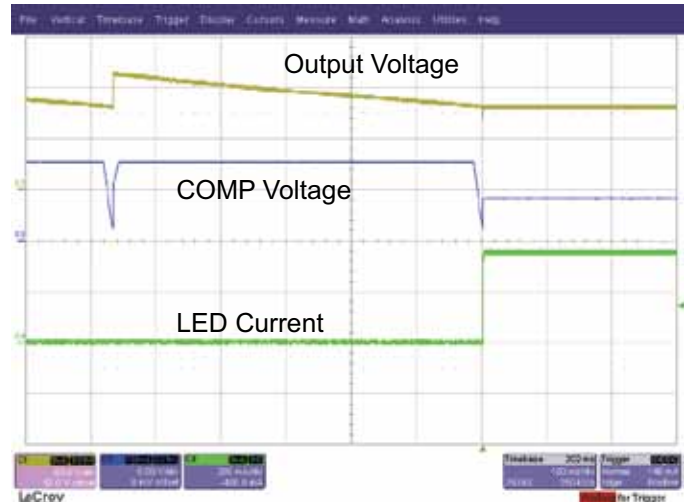


**Fig. 5 Input Under-Voltage Behavior**

**4. Open LED Protection:** Figs 6 and 7 show the hiccup-mode over voltage protection. Fig. 6 shows the open LED condition occurs when the LED current goes to zero. At that point, the inductor current charges the output capacitor and the COMP voltage rails to  $V_{DD}$ . Once the output voltage reaches the over voltage threshold, the converter shuts down and the output voltage slowly decays because the output capacitor is discharged by the over-voltage sensing resistor network. Once the output voltage falls to 90% of its trip point, the converter tries to restart. Since the fault conditions still persists, the converter shuts down almost immediately. Thus, the HV9912 maintains the output voltage in a band until the LED reconnects.



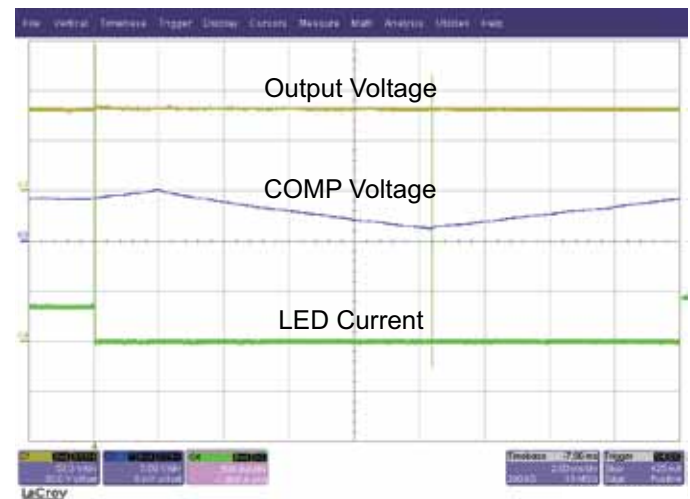
**Fig. 6 Open LED Condition**



**Fig. 7 Recovery from an Open LED Condition**

Fig. 7 shows the recovery of the HV9912DB1 from an over voltage condition. In this case, the LED has reconnected at some point when the converter is turned off. When the converter attempts to restart, it finds the fault condition has disappeared and it starts up normally. There is no overshoot in the LED current .

**Short Circuit Protection:** Figs 8 and 9 show the operation of the short circuit protection in the HV9912DB1. In Fig. 8, the onset of the output short circuit is indicated by the first spike in the LED current. At this point, the HV9912DB1 shuts down and the hiccup mode protection takes over. A constant current source charges the COMP pin to 5.0V and then another current source discharges it to 1.0V. This charge/discharge cycle determines the hiccup time. When the COMP pin reaches 1.0V, the converter attempts to restart and finding the fault condition still present, shuts down again.

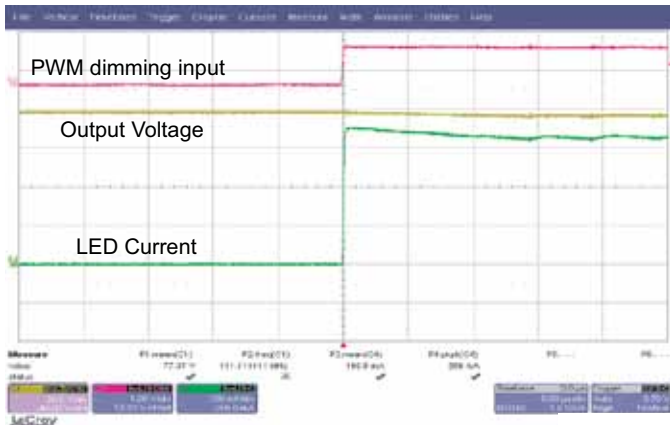


**Fig. 8 Short Circuit Condition**

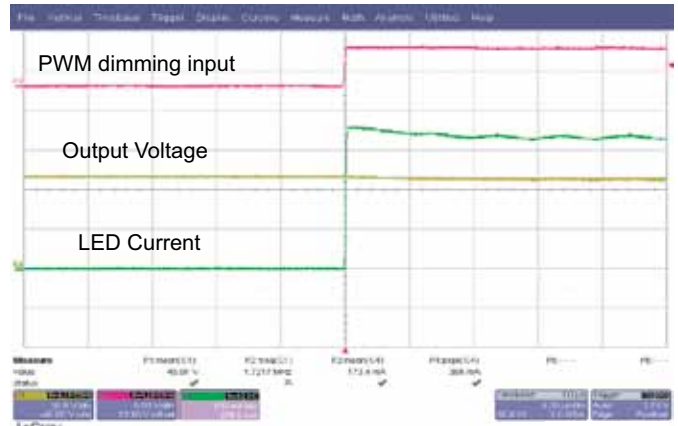
Fig. 9 shows the recovery of the HV9912DB1 from a short circuit condition. It can be seen that the LED current recovers normally with no overshoots.

at output voltages of 80V and 40V respectively. The timescale for all waveforms is set at  $5.0\mu\text{s}/\text{div}$ . The rise and fall times are less than  $1.0\mu\text{s}$  in each case. Thus, a PWM dimming ratio of 1:3000 is achievable at a PWM dimming frequency of 200Hz.

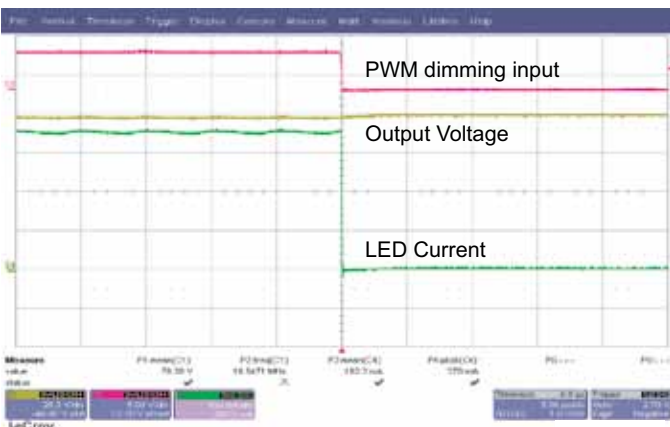
**6. PWM Dimming:** The rise and fall transitions of the LED current during PWM dimming are shown in Figs. 10 and 11,



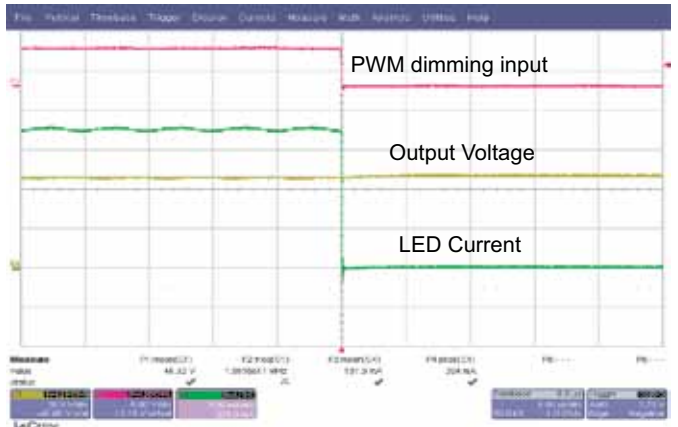
**Fig. 10a Rise time of LED Current at 80V output ( $5.0\mu\text{s}/\text{div}$ )**



**Fig. 11a Rise time of LED Current at 40V output ( $5.0\mu\text{s}/\text{div}$ )**

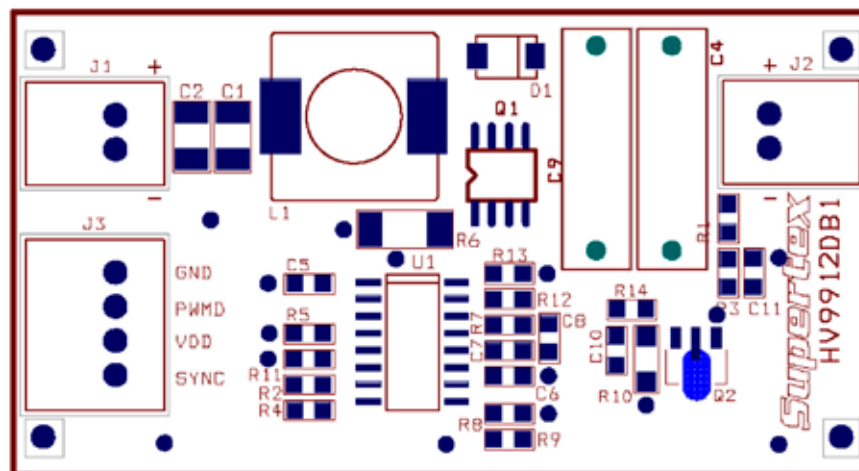


**Fig. 10b Fall time of LED Current at 80V output ( $5.0\mu\text{s}/\text{div}$ )**



**Fig. 11b Fall time of LED Current at 40V output ( $5.0\mu\text{s}/\text{div}$ )**

## Silk Screen





## Bill of Materials

#	Quan	Ref Des	Description	Package	Manufacturer	Manufacturer's Part Number
1	2	C1,C2	2.2 $\mu$ F, 25V, X7R ceramic chip capacitor	SMD1210	TDK Corp	C3225X7R1H225K
2	2	C4,C9	1 $\mu$ F, 100V metal polyester capacitor	Radial	EPCOS Inc	B32522C1105J
3	1	C5	1 $\mu$ F, 16V X7R ceramic chip capacitor	SMD0805	TDK Corp	C2012X7R1C105K
4	1	C6	0.1 $\mu$ F, 16V X7R ceramic chip capacitor	SMD0805	Murata	GRM219R71C104KA01D
5	1	C7	2.2nF, 5%, 50V C0G ceramic chip capacitor	SMD0805	TDK Corp	C2012C0G1H222J
6	1	C8	6.8nF, 5%, 50V C0G ceramic chip capacitor	SMD0805	TDK Corp	C2012C0G1H682J
7	1	C11	10nF, 50V X7R ceramic chip capacitor	SMD0805	TDK Corp	C2012X7R1H103K
8	1	D1	100V, 1.0A schottky diode	SMA	Diodes Inc.	B1100-13
9	2	J1,J2	Side Entry 2-pin male header	Thru-Hole	JST Sales	S2B-EH
10	1	J3	Side Entry 4-pin male header	Thru-Hole	JST Sales	S4B-EH
11	1	L1	220 $\mu$ H, 2.0A sat, 1.5A rms inductor	SMT	Sumida	CDRH127/LDNP-221MC
12	1	Q1	100V, 4.55A N-Channel MOSFET	SO-8	Fairchild	FDS3692
13	1	Q2	100V, 1.5Q N-Channel MOSFET	SOT-89	Supertex	TN2510N8
14	1	R1	866k $\Omega$ , 1%, 1/8W chip resistor	SMD0805	Yageo	RC0805FR-07866KL
15	1	R2	280k $\Omega$ , 1%, 1/8W chip resistor	SMD0805	Yageo	RC0805FR-07280KL
16	2	R3, R11	49.9k $\Omega$ , 1%, 1/8W chip resistor	SMD0805	Yageo	RC0805FR-0749K9L
17	1	R4, C10	open	---	---	---
18	1	R5	1.0k $\Omega$ , 1%, 1/8W chip resistor	SMD0805	Yageo	RC0805FR-071KL
19	1	R6	0.15 $\Omega$ , 1%, 1/2W chip resistor	SMD2010	Vishay/ Dale	WSL2010R1500FEA
20	1	R7	20k $\Omega$ , 1%, 1/8W chip resistor	SMD0805	Yageo	RC0805FR-0720KL
21	1	R8	17.4k $\Omega$ , 1%, 1/8W chip resistor	SMD0805	Yageo	RC0805FR-0717K4L
22	1	R9	7.87k $\Omega$ , 1%, 1/8W chip resistor	SMD0805	Yageo	RC0805FR-077K87L
23	1	R10	1.24 $\Omega$ , 1%, 1/4W chip resistor	SMD1206	Yageo	RC1206FR-071R24L
24	1	R12	16.2k $\Omega$ , 1%, 1/8W chip resistor	SMD0805	Yageo	RC0805FR-0716K2L
25	1	R13	8.66k $\Omega$ , 1%, 1/8W chip resistor	SMD0805	Yageo	RC0805FR-078K66L
26	1	R14	0.0 $\Omega$ , 1/8W chip resistor	SMD0805	Panasonic	ERJ-6GEY0R00V
27	1	U1	Switchmode LED Driver with High Current Accuracy	SO-16	Supertex	HV9912NG

**Supertex inc.** does not recommend the use of its products in life support applications, and will not knowingly sell them for use in such applications unless it receives an adequate "product liability indemnification insurance agreement." **Supertex inc.** does not assume responsibility for use of devices described, and limits its liability to the replacement of the devices determined defective due to workmanship. No responsibility is assumed for possible omissions and inaccuracies. Circuitry and specifications are subject to change without notice. For the latest product specifications refer to the **Supertex inc.** (website: <http://www.supertex.com>)