

**Product  
Summary  
Sheet**

**Switch-mode LED Driver IC  
with High Current Accuracy**

**Applications:**

- ▶ Automotive LED Lighting
- ▶ RGB LED Backlight
- ▶ DC/DC LED Driver Modules
- ▶ Battery Powered LED Lamps



16-Lead SOIC (NG)

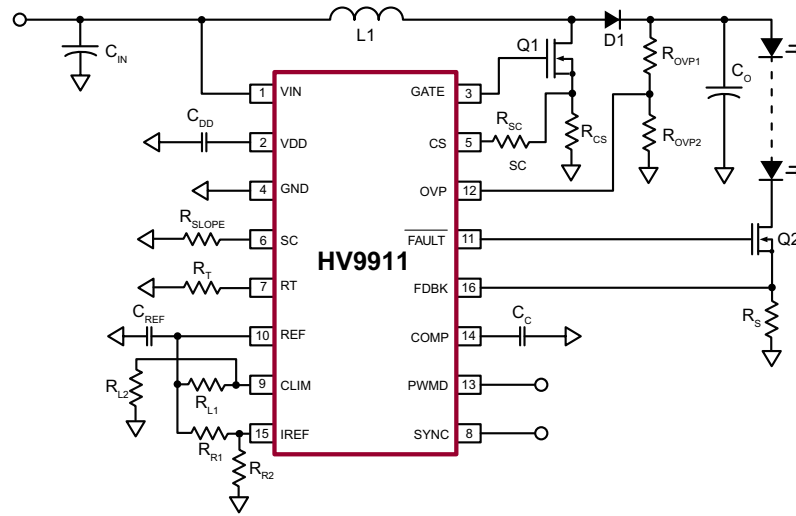

Typical Application Circuit

**Product Overview:**

The HV9911 is a current mode control LED driver IC designed to control single switch PWM converters in a constant frequency or fixed off-time mode. The controller uses a peak current control scheme (with programmable slope compensation) and includes an internal transconductance amplifier to control the output current in closed loop enabling high LED current accuracy and good transient response. HV9911 can be synchronized using the SYNC pin to eliminate any beat frequency or sub-harmonic noise when using multiple LED drivers. Programmable input current limit enables current limiting during input under voltage and output overload conditions. The IC also includes internal protection features for open LED over voltage and output short circuit. A high voltage internal regulator allows operation from 9 to 250V. The HV9911 provides a PWM dimming input that can accept an external control signal with a duty ratio of 0-100% and a frequency of up to a few kilohertz. Linear dimming (LED current adjustment) can be implemented using the reference input to the internal amplifier.

The HV9911 based LED driver is ideal for RGB LED backlight applications where LED current accuracy is needed. The HV9911 based LED drivers can be used in boost, buck and buck-boost (flyback) topologies.

| Features:   | Benefits:  |
|---|--|
| Internal Transconductance Op Amp                                  | Closed loop system. Tighter line and load regulation of the LED current with good transient response to PWM dimming          |
| Synchronization   | Prevent sub-harmonic oscillations associated with driving multiple LED drivers - phase control operation with external clock |
| Fixed frequency or fixed off-time operation                       | Flexibility in use of various converter topologies: Boost, Fly-back, and Buck  |
| Programmable internal OVP comparator and short circuit protection | Integrated open LED and output short circuit protection  |
| Slope compensation  | Allows for wider range of operation (larger strings of LED) in fixed frequency mode  |
| PWM and linear dimming  | Digital and analog control for LED current   |
| Internal 9-250V regulator   | Low voltage and high voltage applications.<br>(Can be extended to 450V with one 200V external zener.)                        |



## Switch-mode LED Driver IC with High Current Accuracy

### Ordering Information / Availability

| <u>Part Number</u> | <u>Package Option</u> | <u>Samples</u> | <u>Lead Time</u> |
|--------------------|-----------------------|----------------|------------------|
| HV9911NG-G         | 16 Pin SOIC (Green)   | Now            | 4-5 Weeks        |

-G indicates the part is RoHS compliant (Green).



### Product Contact

For any questions regarding the HV9911 please contact your local area Supertex sales office, or contact the main office in the US at:

Telephone: 800-222-9888  
Fax: 408-222-4895  
EMail: [mktg@supertex.com](mailto:mktg@supertex.com)  
Website: [www.supertex.com](http://www.supertex.com)

***Supertex inc.***  
1235 Bordeaux Drive, Sunnyvale, CA 94089