

Low Noise, Dimmable EL Lamp Driver Demoboard

General Description

The Supertex HV860DB1 demoboard contains all necessary circuitry to demonstrate the features of the HV860 EL lamp driver.

Simply connect it to a power supply and a lamp as shown in Figure 1. For EL lamp dimming, either a potentiometer or an n-channel open drain PWM signal can be used, but not both.

The potentiometer is used as a variable voltage divider to change the voltage at the V_{REG} pin. The V_{REF} is voltage divided to change the V_{REG} voltage thereby changing the V_{CS} voltage. The V_{CS} voltage amplitude, and thereby the lamp brightness, increases when the potentiometer is rotated counter-clockwise, and the lamp brightness decreases when it is rotated clockwise.

Specifications

Parameter	Value
Input voltage:	2.4 to 4.5V
V_{IN} inductor supply voltage:	5.5V
Typical supply current:	10mA
Lamp size:	3.5in ²
Lamp frequency:	200Hz
Converter frequency:	150kHz

Board Layout and Connection Diagram



Actual Dimensions: 20mm x 25mm

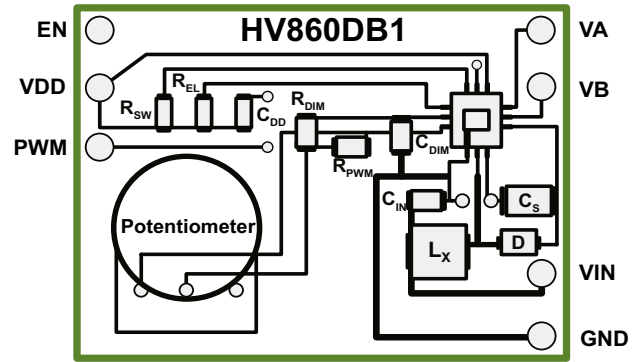

Connections:

EN - (Enable Input)

A CMOS logic input which enables/disables the lamp driver. A logic high (1.5V) enables the driver and a logic low (connect to GND) disables the driver.

V_{DD} - (IC Supply)

Supplies the HV860 EL driver IC. The supplied demo board is optimized for 3.0V operation, with an operating range from 2.4V to 4.5V. It connects to the positive terminal of a power supply.

PWM - (PWM Input)

Supplies the PWM signal for dimming the EL lamp. The frequency of this signal can vary between 20kHz and 100kHz. For EL lamp dimming using the PWM input, either the potentiometer has to be removed or its value set to for maximum lamp brightness.

The n-channel open drain PWM signal pulls the 10k Ω resistor to ground. When the duty cycle of this PWM signal is changed, the

Note:

All of the above connections must be made before powering up the supply voltages.
The V_{REG} pin should not be touched after power-up.

effective voltage on the V_{REG} pin is changed. This changes the V_{CS} voltage, and hence the lamp brightness. The higher the duty cycle, the higher the lamp brightness, and vice versa.

V_A and V_B - (Lamp Connections)

They connect to the EL lamp terminals. Polarity is irrelevant.

V_{IN} - (Inductor Supply)

Supplies the high voltage power converter. The demo board is optimized for 5.5V operation. It connects to the positive terminal of a power supply.

GND - (Circuit Ground)

Connect to V_{DD} and V_{IN} negative terminals. Supply bypass capacitor for both V_{DD} and V_{IN} are provided on the demo board. External supply bypass capacitors are not required.

Figure 1: Circuit Schematic

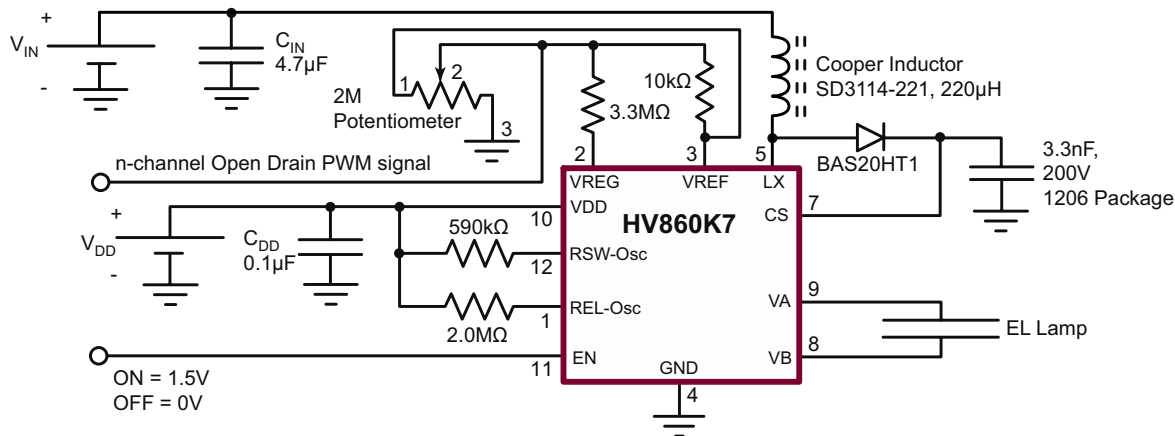

Typical Performance

The specific external components used in the circuit schematic are: $L_x = 220\mu\text{H}$ Cooper (SD3114-221), $C_s = 3.3\text{nF}$ 200V NPO and the $2\text{M}\Omega$ potentiometer.

Lamp Size (in ²)	V _{DD} (V)	V _{IN} (V)	I _{IN} (mA)	V _{CS} (V)	f _{EL} (Hz)	Brightness	
						ft-lm	cd/m ²
3.5	3.0	5.2	9.0	110	190	6.20	21.21
3.5	3.0	5.5	8.4	110	190	6.22	21.27
3.5	3.0	5.8	7.9	110	190	6.24	21.33

Bill of Materials

Component	Description	Package	Manufacturer	Part Number
L _x	220µH inductor	---	Cooper	SD3114-221
C _s	3.3nF, 200V, NPO chip capacitor	1206	Tecate	CMC-200/332JN1206T
R _{sw}	1%, 590kΩ chip resistor	0603	Any	---
R _{EL}	1%, 2MΩ chip resistor	0603	Any	---
R _{DIM}	5%, 3.3MΩ chip resistor	0603	Any	---
R _{PWM}	1%, 10kΩ chip resistor	0603	Any	---
C _{DIM}	Optional capacitor for dimming control	---	---	---
C _{IN}	4.7µF, 10V ceramic chip capacitor	0603	Any	---
C _{DD}	0.1µF, 16V ceramic chip capacitor	0603	Any	---
Diode	200V fast recovery diode	SOD-323	Diodes Inc.	BAS20HT1
POT	2MΩ Potentiometer	---	Bourns Inc.	3352T-205
U1	EL driver IC	12-Lead QFN	Supertex	HV860K7

Note:

The above circuit may be optimized further based on specification of the lamp used.

Supertex inc. does not recommend the use of its products in life support applications, and will not knowingly sell them for use in such applications unless it receives an adequate "product liability indemnification insurance agreement." **Supertex inc.** does not assume responsibility for use of devices described, and limits its liability to the replacement of the devices determined defective due to workmanship. No responsibility is assumed for possible omissions and inaccuracies. Circuitry and specifications are subject to change without notice. For the latest product specifications refer to the **Supertex inc.** (website: <http://www.supertex.com>)