

Low Noise, High Voltage EL Lamp Driver IC Demoboard

General Description

The Supertex HV857LDB1 demoboard contains all necessary circuitry to demonstrate the features of the HV857L EL lamp driver.

Simply connect it to a power supply and a lamp. For additional assistance in designing EL driver circuits, please refer to application notes **AN-H33 (effect of external components on performance of Supertex EL drivers)**.

Specifications

Parameter	Value
Input voltage:	1.8 to 5.0V
Typical supply current:	27mA
Lamp size:	3.0in ²
Lamp frequency:	204Hz
Converter frequency:	70kHz

Board Layout and Connection Diagram

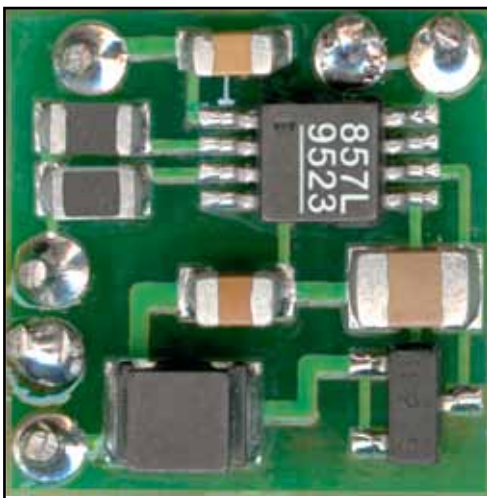

Actual Dimensions: 12mm x 12mm

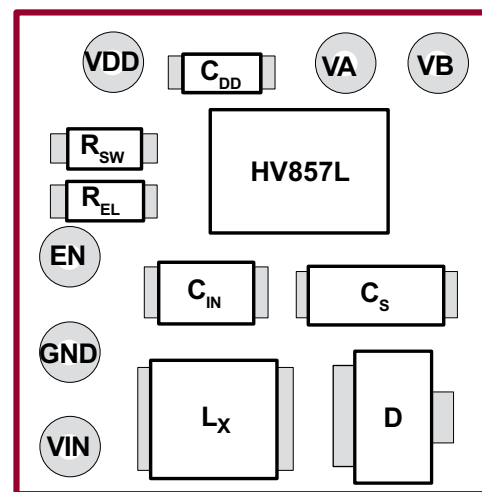

Connections:

EN - Enable Input

Enables/Disables the lamp driver. A logic high, (connect to V_{DD}) enables the driver and a logic low, (connect to GND) disables the driver. This input can be connected to a mechanical switch or to a logic circuit output that has a source impedance of less than 20kΩ.

V_{DD} - IC Supply

Supplies the HV857L EL driver IC. The supplied circuit is optimized for 3.0V operation. The operating range can be from 1.8 to 5.0V. Connect to the positive terminal of a power supply.

Note:

Make sure all the above connections are made before powering up the supply voltages.

V_{IN} - Inductor Supply

Supplies the high voltage power converter. Connect to the positive terminal of a power supply.

GND - Circuit Ground

Connect to V_{DD} and V_{IN} negative terminals. Supply bypass capacitors for both V_{DD} and V_{IN} are provided on the demo board. External supply bypass capacitors are not required.

V_A and V_B - Lamp Connections

Connect to an EL lamp. Polarity is irrelevant.

Circuit Schematic

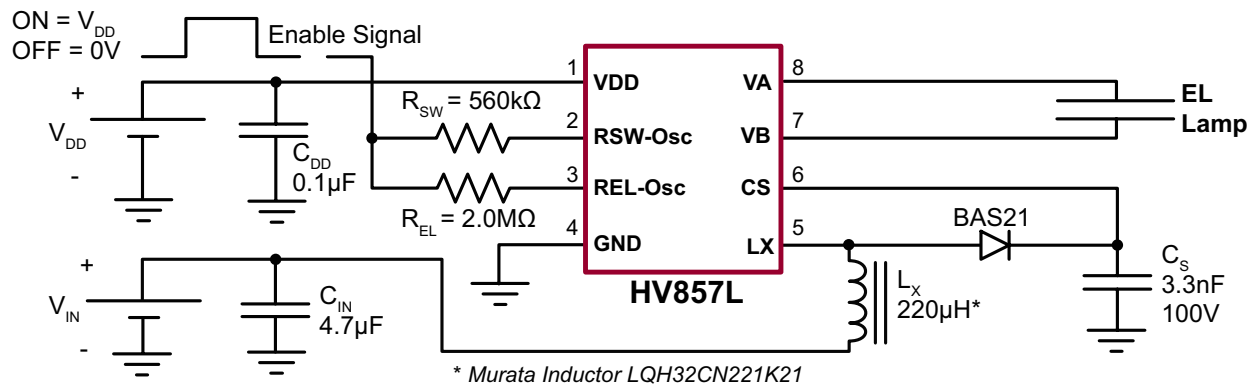

The above circuit may be optimized further based on specification of the lamp used.

Typical Performance

Lamp Size (in ²)	V _{DD} = V _{IN} (V)	I _{IN} (mA)	V _{CS} (V)	f _{EL} (Hz)	Brightness	
					ft-lm	cd/m ²
3.0	1.8	27.06	70	202	2.49	8.51
3.0	2.0	26.95	73	202	3.04	10.40
3.0	3.0	27.01	90	204	5.49	18.78
3.0	4.0	21.94	96	204	5.97	20.42
3.0	5.0	17.55	98	204	6.24	21.33

Bill of Materials

Component	Description	Package	Manufacturer	Part #
L _x	220μH Inductor	-	Murata	LQH32CN221K21
C _s	3.3nF, 100V, NPO chip capacitor	0805	Novacap	0805N332K101NT
R _{SW}	5%, 560kΩ resistor	0805	Any	---
R _{EL}	5%, 2MΩ resistor	0805	Any	---
C _{IN}	4.7μF, 10V ceramic chip capacitor	0805	Any	---
C _{DD}	0.1μF, 16V ceramic chip capacitor	0603	Any	---
Diode	250V fast recovery diode	SOT-23	Diodes Inc	BAS21
U1	EL driver IC	MSOP-8	Supertex Inc	HV857LMG-G

Supertex inc. does not recommend the use of its products in life support applications, and will not knowingly sell them for use in such applications unless it receives an adequate "product liability indemnification insurance agreement." **Supertex inc.** does not assume responsibility for use of devices described, and limits its liability to the replacement of the devices determined defective due to workmanship. No responsibility is assumed for possible omissions and inaccuracies. Circuitry and specifications are subject to change without notice. For the latest product specifications refer to the **Supertex inc.** (website: <http://www.supertex.com>)