

## High Voltage, Low Noise, Inductorless EL Lamp Driver Demoboard

### General Description

The Supertex HV853DB1 demoboard contains all the necessary circuitry to demonstrate the features of the HV853 EL lamp driver. The HV853 is the low noise version of the EL driver HV852 with improved EMI performance.

Simply connect it to a power supply and a lamp as shown in Figure 1. For additional assistance with the HV853 demoboard circuit, please refer to the HV853 datasheet.

### Specifications

Parameter	Value
Input voltage:	3.2V to 5.0V
Supply current:	18mA
Lamp size:	0.93in <sup>2</sup> and 1.5in <sup>2</sup>
Lamp frequency:	274Hz

### Board Layout and Connection Diagram



Actual Dimensions: 13mm x 8mm

### Connections:

#### V<sub>DD</sub> (IC Supply)

Supplies the HV853 EL driver IC. The supplied demoboard is optimized for 3.2 to 5.0V operation.

#### EN (Enable Input)

A logic input which enables/disables the driver. Connect EN to logic high (V<sub>DD</sub>) to enable the driver and to logic low (GND) to disable the driver. This input may be connected to a mechanical switch or to a logic circuit output.

#### CLK<sub>IN</sub> (Clock Input)

A logic input pin to which an external clock can be applied to set the EL lamp frequency. CLK<sub>EN</sub> has to be connected to V<sub>DD</sub> when external clock input is used. Also, the R<sub>EL</sub> resistor needs to be removed and the R<sub>EL</sub> pin needs to be connected to ground. Connect CLK<sub>IN</sub> to GND if not used.

#### Note:

All of the above connections must be made before powering up the supply voltages.

#### GND (Circuit Ground)

Connect to V<sub>DD</sub> negative terminal. Supply bypass capacitor for V<sub>DD</sub> is provided on the demoboard. External supply bypass capacitors are not required.

#### V<sub>A</sub> and V<sub>B</sub> (Lamp Connections)

They connect to EL lamp terminals. Polarity is irrelevant.

#### CLK<sub>EN</sub> (Clock Enable)

Logic input pin which enables/disables the external clock applied. Logic high (V<sub>DD</sub>) will cause the EL lamp frequency to be set by the CLK<sub>IN</sub> input. Logic low (GND) will cause the EL lamp frequency to be set by the external R<sub>EL</sub> resistor.

**Figure 1: Test Circuit**

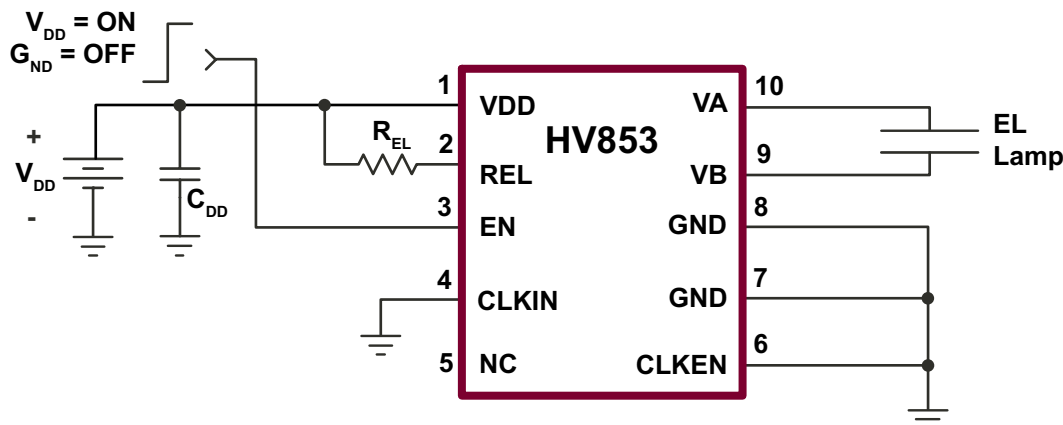

## Test Circuit Data

The specific external components used in the above circuit are:  $C_{DD} = 2.2\mu\text{F}$ , 6.3V ceramic capacitor and  $R_{EL} = 1.6\text{M}\Omega$ . The following was observed when driving a 0.93in<sup>2</sup> green lamp and 1.5in<sup>2</sup> green lamp.

Lamp Size (in <sup>2</sup> )	$V_{DD}$ (V)	$I_{DD}$ (mA)	$V_{PEAK}$ (V)	$f_{EL}$ (Hz)	Brightness	
					ft-lm	cd/m <sup>2</sup>
0.93	3.2	12.6	79	274	5.71	19.53
0.93	3.7	11.7	79	274	5.91	20.20
0.93	4.2	11.4	79	274	6.08	20.80
0.93	5.0	11.2	79	274	6.20	21.21
1.50	3.2	17.6	79	274	5.27	18.03
1.50	3.7	17.1	79	274	5.60	19.15
1.50	4.2	16.8	79	274	5.80	19.85
1.50	5.0	16.5	79	274	6.00	20.52

## Bill of Materials

Component	Description	Package	Manufacturer	Part Number
$R_{EL}$	1%, 1.6M $\Omega$ chip resistor	0603	Any	---
$C_{DD}$	2.2 $\mu\text{F}$ , 6.3V ceramic chip capacitor	0603	Any	---
U1	EL driver IC	DFN-10	Supertex	HV853K7-G

**Note:**

The above circuit may be optimized further based on specification of the lamp used.

**Supertex inc.** does not recommend the use of its products in life support applications, and will not knowingly sell them for use in such applications unless it receives an adequate "product liability indemnification insurance agreement." **Supertex inc.** does not assume responsibility for use of devices described, and limits its liability to the replacement of the devices determined defective due to workmanship. No responsibility is assumed for possible omissions and inaccuracies. Circuitry and specifications are subject to change without notice. For the latest product specifications refer to the **Supertex inc.** (website: <http://www.supertex.com>)