

+24V/+48V Fan Driver/Controller Demoboard

General Description

The Supertex HV7100DB1 is a fan controller/driver designed to operate from +24 or +48V supplies. Fan speed is controlled by pulse width modulating the supply voltage provided to the fans. For fans that do not work properly with a PWM supply, an included daughter board contains an LC filter for converting the pulse width modulated output of the main board to a DC output voltage.

On-board controls allow adjustment of the fan speed. Alternatively, the fan speed may be controlled using externally applied signals.

Specifications

Parameter	Value
Supply voltage	+16V to +75V
Supply current, typical, no load	3.0mA
Output current (max)	1.3A
PWM frequency (jumper selectable)	60Hz, 600Hz, 6kHz, 60kHz

Board Layout and Connection Diagram

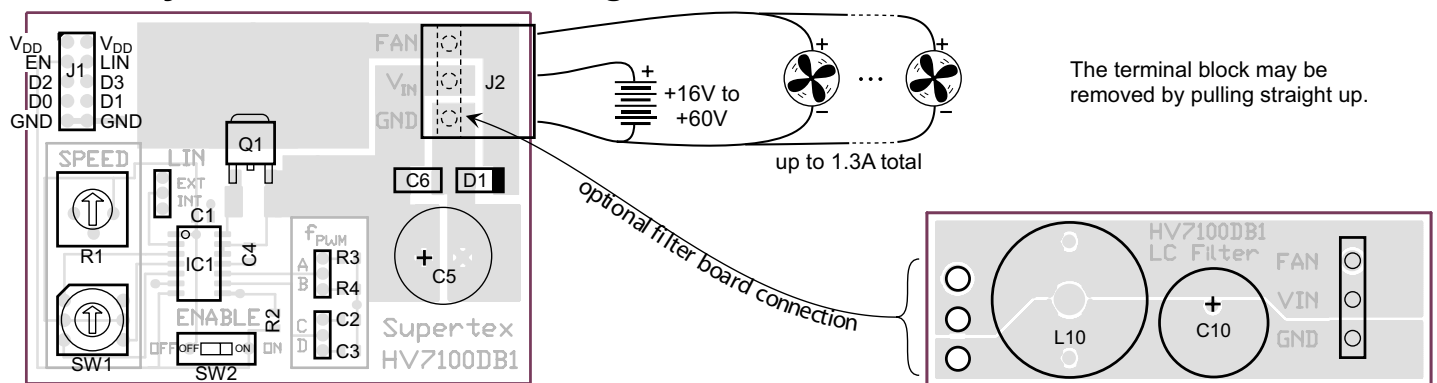

Connections and Controls:

V_{IN}
Connect to a +16 to +75V supply.

GND
Circuit common.

FAN
Connect the fan(s) between the fan and ground terminals as shown above. Fan load should not exceed 1.3A.

ENABLE
Setting the ENABLE switch to OFF disables the fan(s).

Speed
The fan speed may be controlled in 2 ways: linear or digital. The upper, linear control (R₁) varies duty cycle continuously. The lower speed control (SW₁) is digital, with fan speed set in 16 steps from off to full on. The higher fan speed setting, linear or digital, dominates.

External Control (J1)
When using external signals to control the HV7100DB1, set the digital speed control to zero, set the on-board linear control fully CCW, and set the ENABLE switch to OFF. When using an external linear control signal, set the L_{IN} jumper to EXT.

Logic levels are: 0 < 0.9V; 1 > 2.52V.

Linear Control Selection (LIN) - With the LIN jumper set to INT and digital speed control set to 0, fan speed is controlled using the on-board potentiometer (R1). When set to EXT, fan speed is controlled by a voltage applied to the LIN pin on connector J1.

Duty cycle is given by:

$$D = \frac{V_{LIN}}{2} - 0.25$$

f_{PWM} - PWM switching frequency may be adjusted by setting the f_{PWM} jumpers as follows:

f	A	B	C	D
60Hz	-	x	-	x
600Hz	x	-	-	x
6kHz	-	x	x	-
60kHz	x	-	x	-

LC Filter Board - Without the filter board, the HV7100DB1 drives the fans with a PWM supply voltage. Some fans may not work properly when driven in this manner, instead preferring a steady DC voltage. The filter board filters out the PWM frequency, providing a DC voltage to drive the fans.

Remove the terminal block from the main board, move it to the LC filter board, then plug the filter board onto the main board. When using the filter board, set f_{PWM} to 60kHz.

Schematic

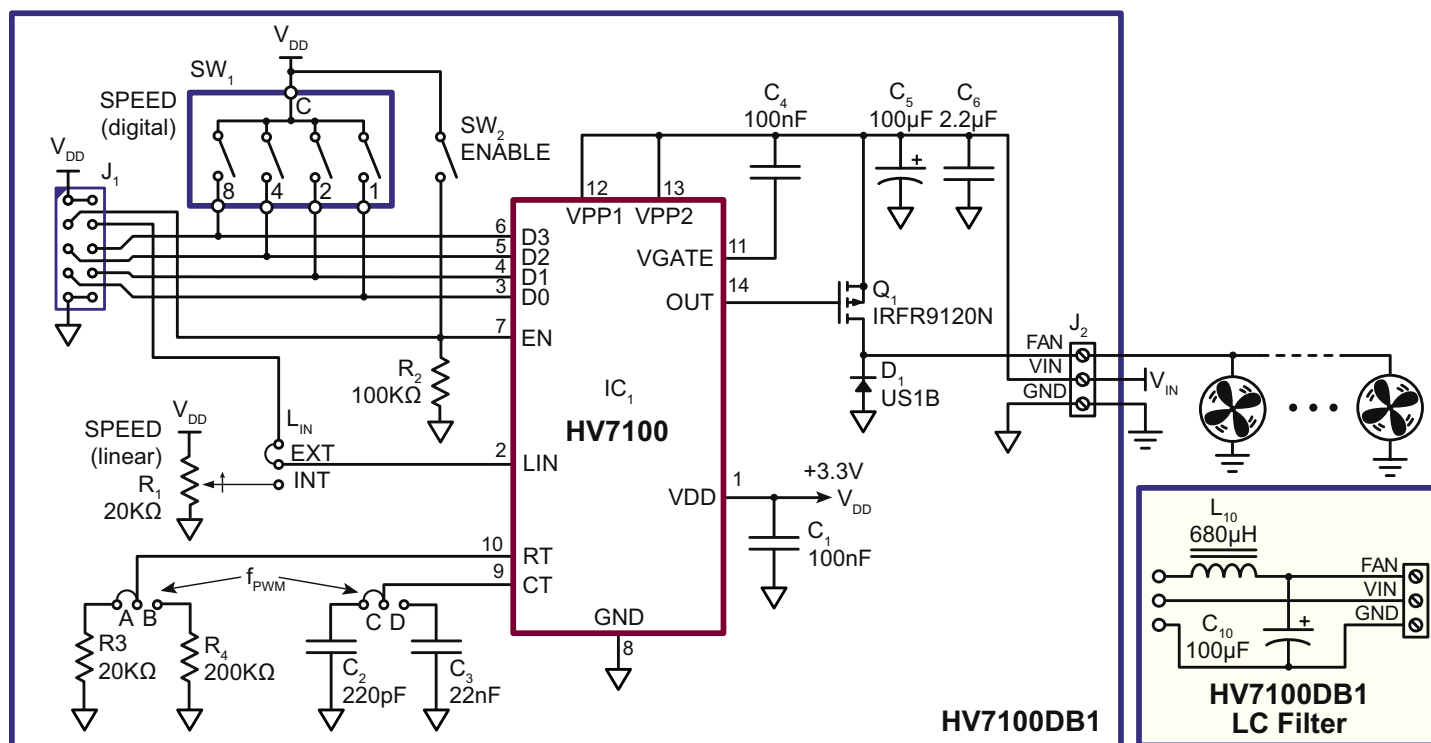

Bill of Materials

Part	Description	Value	Tolerance	Rating	Package	Mfg.	Mfg. Part Number
Main Board							
SW1	Hexadecimal rotary switch	-	-	-	-	Apem	PT65303
SW2	Switch, SPST	-	-	-	-	-	-
R1	Potentiometer	20k Ω	10%	-	-	Vishay	063P203T607
R2	Resistor	100k Ω	5%	100mW	0805	-	-
R3	Resistor	20k Ω	1%	100mW	0805	-	-
R4	Resistor	200k Ω	1%	100mW	0805	-	-
C1	Capacitor, ceramic X7R	100nF	10%	10V	0805	-	-
C2	Capacitor, ceramic NPO	220pF	5%	10V	0805	-	-
C3	Capacitor, ceramic X7R	22nF	10%	10V	0805	-	-
C4	Capacitor, ceramic X7R	100nF	10%	20V	0805	-	-
C5	Capacitor, alum lo ESR	100 μ F	20%	100V, 800mA	-	Tecate	TRS-100/101M12x20
C6	Capacitor, ceramic X7R	2.2 μ F	20%	100V	-	-	-
D1	Diode	-	-	100V, 1.0A	-	-	US1B
Q1	MOSFET, P-channel	-	-	100V, 6.6A	D-Pak	IR	IRFR9120N
IC1	Fan controller	-	-	-	-	Supertex	HV7100NG-G
Filter Board							
C10	Capacitor, alum	100 μ F	20%	100V, 800mA	-	Tecate	TRS-100/101M12x20
L10	Inductor	680 μ H	20%	1.39A	-	Renco	RL-1256-2-680

Supertex inc. does not recommend the use of its products in life support applications, and will not knowingly sell them for use in such applications unless it receives an adequate "product liability indemnification insurance agreement." **Supertex inc.** does not assume responsibility for use of devices described, and limits its liability to the replacement of the devices determined defective due to workmanship. No responsibility is assumed for possible omissions and inaccuracies. Circuitry and specifications are subject to change without notice. For the latest product specifications refer to the **Supertex inc.** (website: <http://www.supertex.com>)