

Product Summary Sheet



**HV2605
HV2705
HV2706**

Low Harmonic Distortion, 16-Channel, High Voltage, Analog Switch ICs

Applications:

- ▶ Medical ultrasound imaging
- ▶ Non-destructive evaluation
- ▶ Piezoelectric transducer drivers
- ▶ Optical MEMS modules

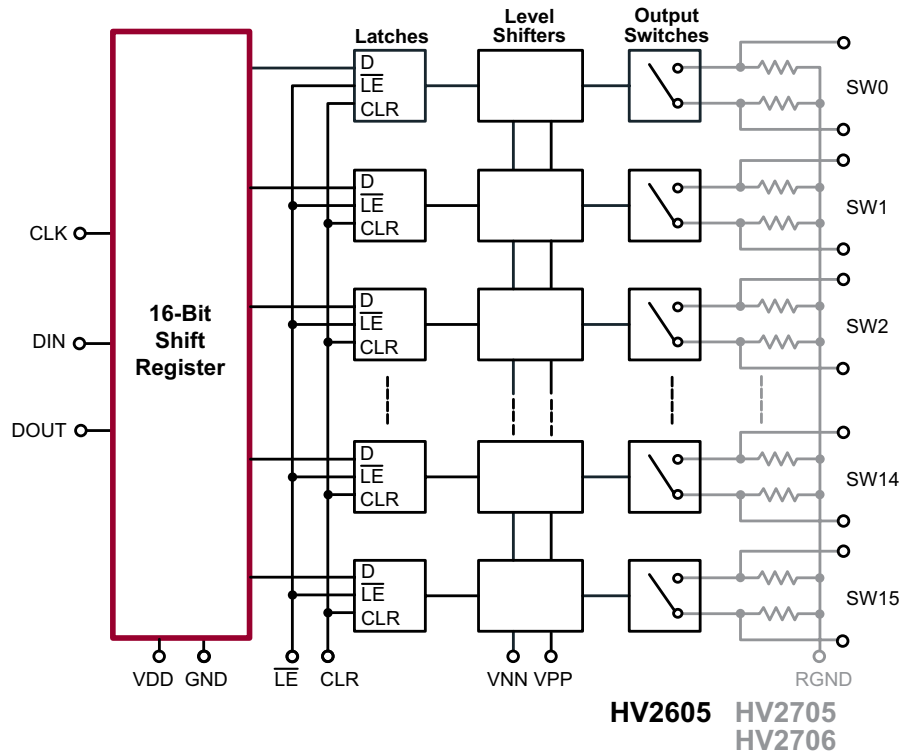

Typical Application Circuit

Product Overview:

The Supertex HV2605, HV2705 and HV2706 are low charge injection, 16-channel, high voltage, analog switches that are ideal for applications requiring high voltage switching controlled by low voltage control signals, such as medical ultrasound imaging and other piezoelectric transducer drivers. The HV2705 and HV2706 have integrated bleed resistors, which eliminate voltage built up on capacitive loads such as piezoelectric transducers. The HV2706 has a different pin configuration than the HV2705.

Input data are shifted into a 16-bit shift register that can then be retained in a 16-bit latch. To reduce any possible clock feed through noise, the latch enable bar should be left high until all bits are clocked in. Data are clocked in during the rising edge of the clock. Using HVCMOS technology, these devices combine high voltage bilateral DMOS switches and low power CMOS logic to provide efficient control of high voltage analog signals. These devices are suitable for various combinations of high voltage supplies, e.g., V_{PP}/V_{NN} : +40V/-160V, +100V/-100V, and +160V/-40V.

Features:	Benefits:
Up to 200V operating voltage	Allows for higher transmit voltages for deeper body tissue imaging capability
22Ω switch resistance	Minimizes return signal attenuation for increased signal-to-noise ratio for clearer images
Low charge injection	Allows for clearer images and faster frame rate
CMOS serial shift register control	Minimizes I/O connections and power dissipation
7mm x 7mm LQFP package	Higher board density



48-Lead LQFP (FG)



062011

Supertex inc

HV2605
HV2705
HV2706

Low Harmonic Distortion, 16-Channel, High Voltage Analog Switch ICs

Ordering Information / Availability

Part Number	Package Option	Samples	Lead Time
HV2605FG-G	48-Lead LQFP (Green)	Now	4-6 Weeks ARO
HV2705FG-G	48-Lead LQFP (Green)	Now	4-6 Weeks ARO
HV2706FG-G	48-Lead LQFP (Green)	Now	4-6 Weeks ARO

-G indicates the part is RoHS compliant (Green).



Product Contact

For any questions regarding the HV2605, HV2705, or the HV2706, please contact your local area Supertex sales office, or contact the main office in the US at:

Telephone: 800-222-8888
Fax: 408-222-4895
EMail: mktg@supertex.com
Website: www.supertex.com

Supertex inc
1235 Bordeaux Drive, Sunnyvale, CA 94089