

High Voltage Amplifier Array

General Description

The Supertex HV254DB1 is a 32-channel 250V amplifier array with a nominal gain of 50V/V. The HV254DB1 provides a means to easily evaluate the Supertex HV254FG device. A high voltage supply, V_{PP} , and two low voltage supplies, $V+$ and $V-$, are required. These connections can be made via the J1 header provided on the board. There are 32 pads on the left side of the board for the input signals and 32 pads on the right for the outputs. Please follow the power up/down sequence to avoid damaging the device.

Specifications

Parameter	Value
V_{PP} , High voltage supply:	275V
$V+$, Low voltage positive supply	4.75 to 5.25V
$V-$, Low voltage negative supply	-4.75 to -5.25V
V_{IN} , Input signal range:	0V to $V+$
HV_{OUT} , Output voltage swing	7.0 to 250V
A_V , Closed loop gain	50V/V \pm 5%
SR, Output slew rate into 100pF load	3.0V/ μ s

Board Layout

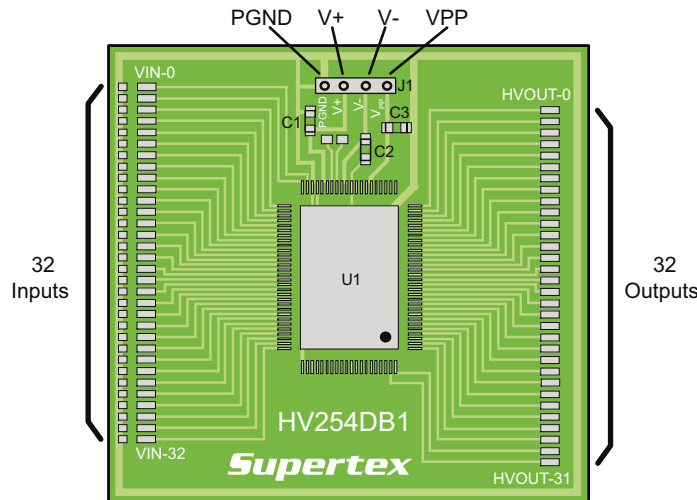

Power Up/Down Sequence

The device can be damaged due to improper power up/down sequence. To prevent such damage, please follow the acceptable power up/down sequences. Two external diodes, D1 and D2, are added in the demo board to prevent damage during power Up/Down. The first diode is a high voltage diode across V_{PP} and $V+$. Any low current high voltage diode such as a 1N4004 will be adequate. The second diode is a Schottky diode across $V-$ and PGND. Any low current Schottky diode such as a 1N5817 will be adequate..

Acceptable Power Up Sequences

- 1) V_{PP} 2) $V-$ 3) $V+$ 4) Inputs & Anode
- or
- 1) $V-$ 2) $V+$ 3) V_{PP} 4) Inputs & Anode

Acceptable Power Down Sequences

- 1) Inputs & Anode 2) V_{PP} 3) $V+$ 4) $V-$
- or
- 1) Inputs & Anode 2) V_{PP} 3) $V-$ 4) $V+$

Inputs and Outputs

The output of the HV254FG will swing from 7.0 to 250V. It cannot swing to ground. With the internal gain set at 50V/V, a minimum input signal of 140mV will still maintain linearity. Input voltages below 140mV can be applied without damage to the device. The amplifier, however, will be saturated.

The maximum input signal can be as high as the positive supply voltage, $V+$. For a $V+$ of 5.0V and an input voltage of 5.0V, the output will be 250V. For additional information, please refer to the HV254 data sheet.

Temperature Diode

The HV254FG has an integrated silicon diode to help monitor the die temperature if desired. Pin 43 is the anode and pin 44 is the cathode. Pads are available on the board for these connections.

Circuit Diagram

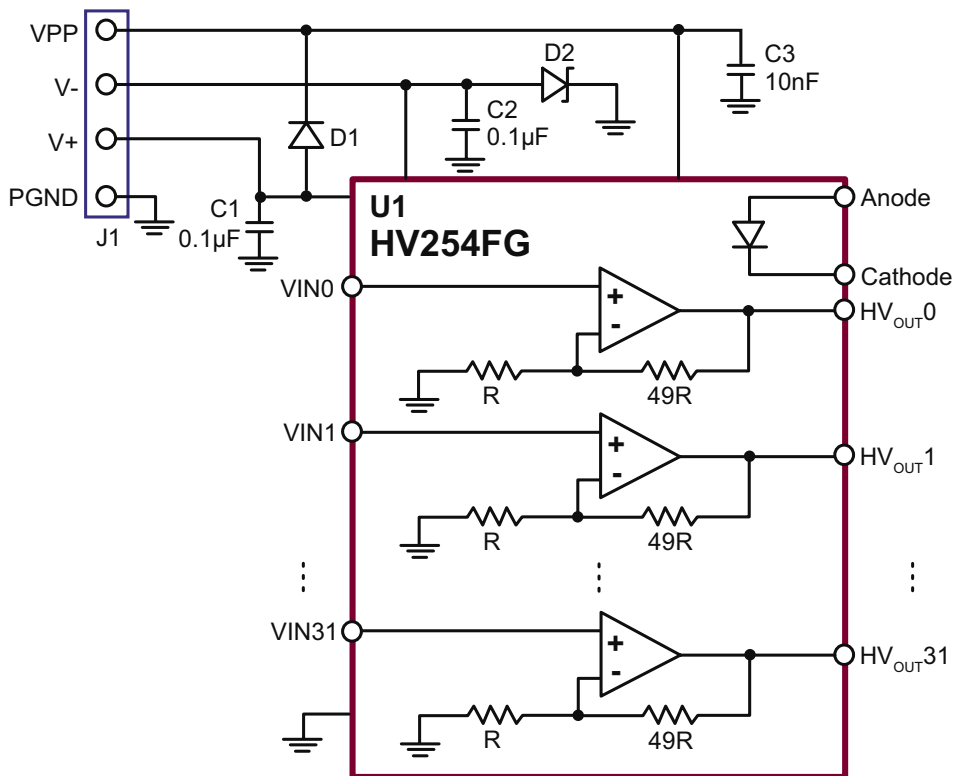

Bill of Materials

Part	Description	Value	Package	Manufacturer	Part Number
C1	X7R chip capacitor	25V, 0.1µF±10%	0805	Tecate	CMC-025104KX0805T
C2	X7R chip capacitor	25V, 0.1µF±10%	0805	Tecate	CMC-025104KX0805T
C3	X7R chip capacitor	500V, 0.01µF±10%	0805	Tecate	CMC-500103KX0805T
J1	Right Angle 4-pin header	0.100", tin plating	---	Molex	22-05-3041
D1	Rectifier diode	400V, 1.0A	DO-41	Any	1N4004
D2	Schottky diode	20V, 1.0A	DO-41	Any	1N5817
U1	Amplifier array	300V	100-Lead MQFP	Supertex	HV254FG

Supertex inc. does not recommend the use of its products in life support applications, and will not knowingly sell them for use in such applications unless it receives an adequate "product liability indemnification insurance agreement." **Supertex inc.** does not assume responsibility for use of devices described, and limits its liability to the replacement of the devices determined defective due to workmanship. No responsibility is assumed for possible omissions and inaccuracies. Circuitry and specifications are subject to change without notice. For the latest product specifications refer to the **Supertex inc.** (website: <http://www.supertex.com>)