

**Product  
Summary  
Sheet**

**Fault Protection Switch  
with  
Current Fold-back**

**Applications:**

- ▶ Power supplies
- ▶ Fast, resettable fuses
- ▶ High side switches
- ▶ Data acquisition



SOT-89 (N8)

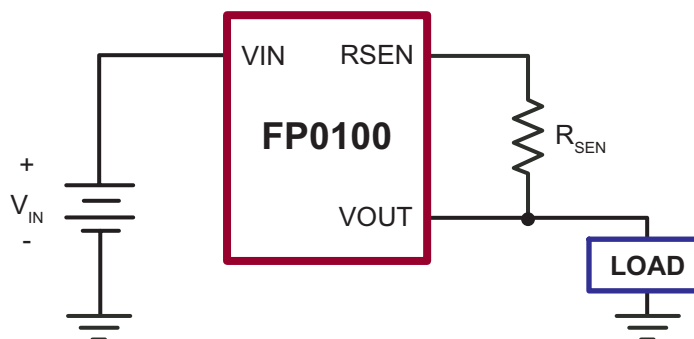

**Typical Application Circuit**

**Product Overview:**

The Supertex FP0100 is a high voltage fault protection switch with current fold-back. It is designed to protect system output power supplies against over-current or short circuit conditions. In protection mode, the FP0100 limits the current to 300µA.

The FP0100 can be considered as a normally closed switch with a typical switch resistance of 4.0Ω. The peak current allowed to pass through the switch can be set by an external resistor across VOUT and RSEN. Once the voltage drop across VIN and VOUT exceeds a nominal value of 3.0V, the input current will fold-back to 300µA. In the off state, the FP0100 can withstand up to 100V. Higher input voltages can be accommodated by using an external depletion-mode MOSFET. Please refer to Figure 2 in the data sheet for more details. The FP0100 is available in a SOT-89 package.

Features:	Benefits:
Up to 100V input voltage protection	Guards downstream circuitry against overcurrent or short circuit conditions
Low on resistance - 4.0Ω typical	Minimizes voltage drop to save power and maintain functionality
Fast switching speed	Protects against abrupt short circuit conditions
No external supplies needed	Ease of use and minimized board area



## Fault Protection Switch with Current Fold-back

### Ordering Information / Availability

Part Number	Package Option	Samples	Lead Time
FP0100N8-G	SOT-89/TO-243AA	Now	4-6 weeks ARO

-G indicates the part is RoHS compliant (Green).



### Product Contact

For any questions regarding the FP0100, please contact your local area Supertex sales office, or contact the main office in the US at:

Telephone: 800-222-8888  
Fax: 408-222-4895  
EMail: [mktg@supertex.com](mailto:mktg@supertex.com)  
Website: [www.supertex.com](http://www.supertex.com)

***Supertex inc.***  
1235 Bordeaux Drive, Sunnyvale, CA 94089