

Isolated LED Driver Using the HV9910B

Introduction

In a few general lighting applications, there is a need to isolate the LEDs from the AC input line. These are cases when the driver terminals of the LED strings are exposed to the external environmental conditions, or the LED strings are user accessible for maintenance during operation. In these cases, an isolated LED driver is needed for safety considerations.

This design note provides the circuit schematic, bill of materials, and transformer design for an isolated LED driver using Supertex's HV9910B. The power stage is a flyback converter with an isolated secondary side feedback, using an opto coupler, to ensure a very good line and load regulation (typically <1% over line and load). Below are the design parameters which are the target specification for this LED driver circuit. This LED driver will also meet CISPR-15 EMI limits for general lighting.

Design Parameters

Parameter	Value
Input voltage	90 – 256VAC, 50/60Hz
LED string voltage	4.0 – 16V
LED current	350mA
Initial regulation	<5%
Line and load regulation	<1%
Over voltage protection	20V
Switching Frequency	100kHz

The information in this datasheet also applies to the Supertex HV9910.

Circuit Schematic

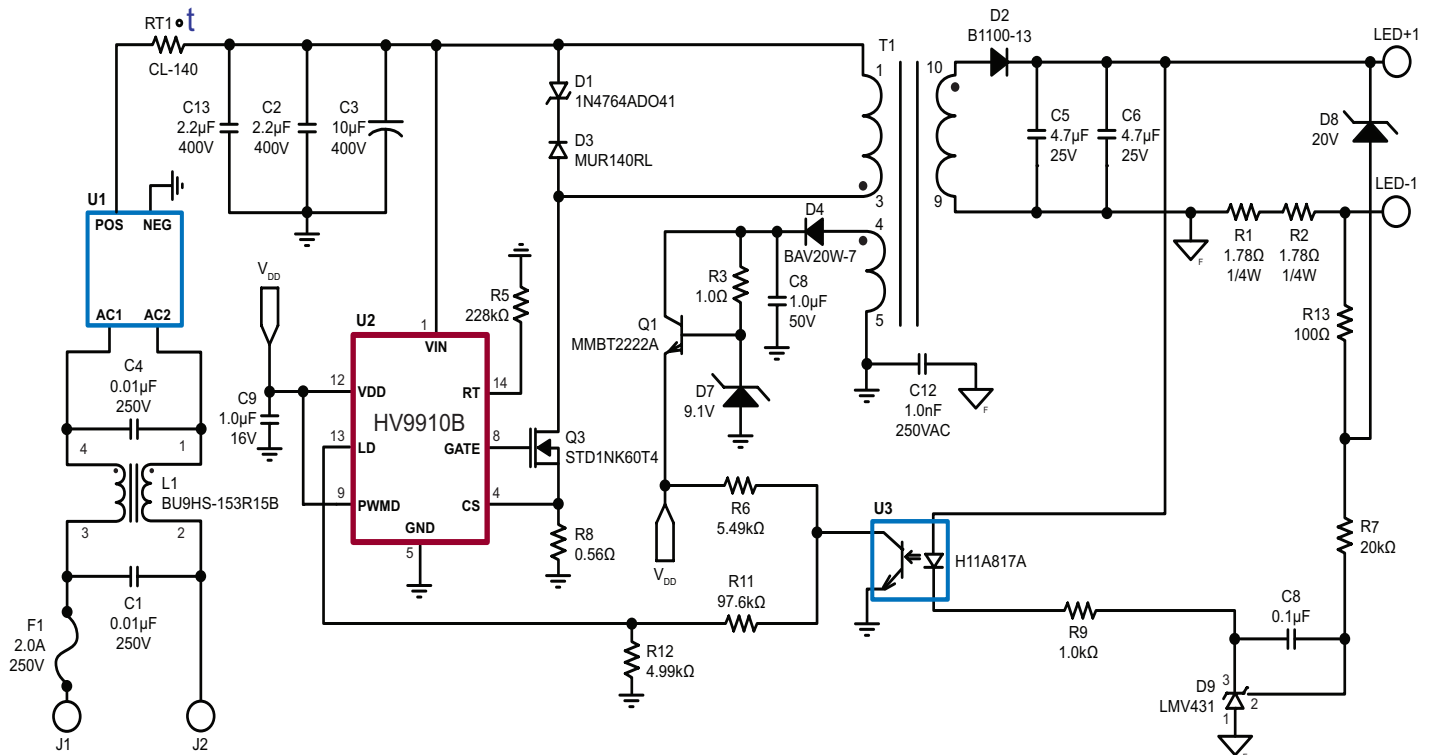

Bill of Materials

Item #	Qty	Ref	Description	Package	Manufacturer	Manufacturer's Part Number
1	2	C1, C4	0.01uF, 250VAC metal polypropylene capacitors	Thru-Hole	EPCOS Inc	B81122A1103M
2	2	C2, C13	2.2uF, 400V metal film capacitors	Thru-Hole	Panasonic	ECQ-E4225KF
3	1	C3	10uF, 400V electrolytic capacitors	Radial	Nichion	UVR2G100MHD
4	2	C5, C6	4.7uF, 25V X7R ceramic chip capacitor	SMD1210	TDK Corporation	C3225X7R1E475M
5	1	C8	1uF, 50V X7R ceramic chip capacitor	SMD1206	TDK Corporation	C3216X7R1H105K
6	1	C9	1uF, 16V X7R ceramic chip capacitor	SMD0805	TDK Corporation	C2012X7R1C105K
7	1	C11	0.1uF, 16V X7R ceramic chip capacitor	SMD0805	Kemet	C0805C104K4RACTU
8	1	C12	1n, 250VAC ceramic capacitor Y2/X1	Thru-Hole	Panasonic	ECK-NVS102ME
9	1	D1	100V, 1W zener diode	DO-41	Micro Semi	1N4764ADO41
10	1	D2	100V, 1A schottky diode	SMA	Diodes Inc	B1100-13
11	1	D3	400V, 1A ultrafast switching diode	DO-41	On Semi	MUR140RL
12	2	D4	150V, 400mA switching diode	SOD123	Diodes Inc	BAV20W-7
13	1	D7	9.1V, 500mW zener diode	SOD123	Diodes Inc	BZT52C9V1-7
14	1	D8	20V, 500mW zener diode	SOD123	Diodes Inc	BZT52C20-7-F
15	1	D9	1.24V, precision shunt regulator	SOT-23	National Semi	LMV431
16	1	F1	2A, 250VAC fuse	Thru-Hole	Cooper/Bussmann	BK/PCB-2
17	1	L1	15mH (300uH differential), 0.15A rms common mode choke	Thru-Hole	Coilcraft	BU9HS-153R15B
18	1	Q1	40V, 600mA NPN transistor	SOT-23	ST Micro	MMBT2222A
19	1	Q3	600V, 1A N-Channel MOSFET	DPAK	ST Micro	STD1NK60T4
20	1	RT1	50ohm Inrush current limiter	Thru-Hole	GE Infrastructure	CL-140
21	2	R1, R2	1.78, 1/4W, 1% chip resistor	SMD0805	Yageo	9C12063A1R78FGHFT
22	2	R3, R9	1k, 1/8W, 1% chip resistor	SMD0805	Yageo	9C08052A1001FKHFT
23	1	R5	226k, 1/8W, 1% chip resistor	SMD0805	Yageo	9C08052A2263FKHFT
24	1	R6	5.49k, 1/8W, 1% chip resistor	SMD0805	Yageo	9C08052A5491FKHFT
25	1	R7	20k, 1/8W, 1% chip resistor	SMD0805	Yageo	9C08052A2002FKHFT
26	1	R8	0.56, 1/8W, 1% chip resistor	SMD0805	Panasonic	ERJ-6RQFR56V
27	1	R11	97.6k, 1/8W, 1% chip resistor	SMD0805	Yageo	9C08052A9762FKHFT
28	1	R12	4.99k, 1/8W, 1% chip resistor	SMD0805	Yageo	9C08052A4991FKHFT
29	1	R13	100 ohm, 1/8W, 1% chip resistor	SMD0805	Yageo	9C08052A1000FKHFT
30	1	T1	Flyback Transformer	-	-	---
31	1	U1	400V, 1A Single Phase diode bridge rectifier	DF-S	Diodes Inc	DF04S
32	1	U2	Universal LED Driver	SO-16	Supertex	HV9910BNG-G
33	1	U3	Single Channel Optoisolator	4-DIP	Fairchild	H11A817A

Flyback Transformer Details

Component	Description
Core :	EFD20/10/7 – 3C90 – A250 from Ferroxcube (EFD 20 core with 160µm gap in the center leg)
Bobbin:	CPHS – EFD20 – 1S – 10P from Ferroxcube
Primary:	66 turns of AWG#32 magnet wire
Secondary:	13 turns of AWG#24 equivalent triple-insulated litz wire
Auxiliary:	32 turns of AWG#32 magnet wire
Insulation:	3M 1928 Polyester Film, 2.0 mil thick tape

Schematic Diagram of the Transformer

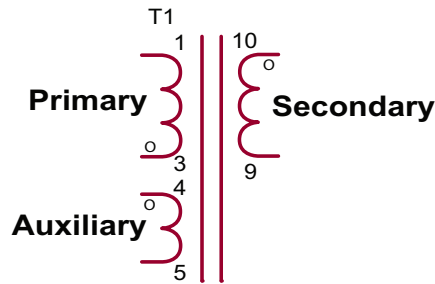

$L_{PRIMARY} = 1.1mH \pm 8\%$
 Leakage inductance = 8% of $L_{PRIMARY}$

Winding Diagram

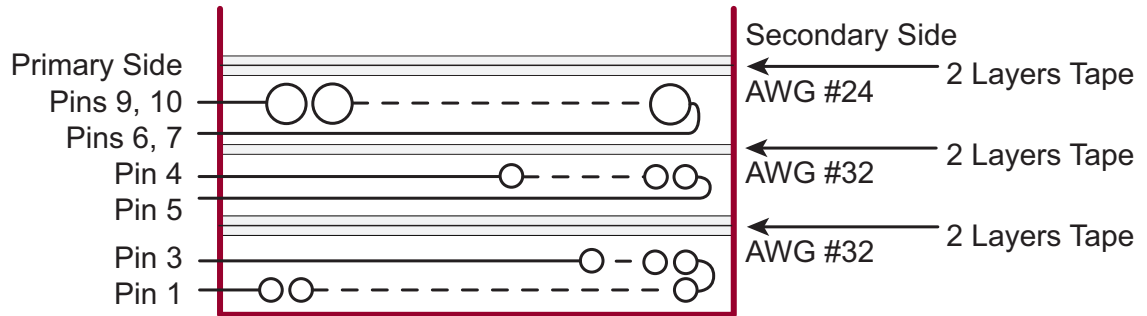

Supertex inc. does not recommend the use of its products in life support applications, and will not knowingly sell them for use in such applications unless it receives an adequate "product liability indemnification insurance agreement." **Supertex inc.** does not assume responsibility for use of devices described, and limits its liability to the replacement of the devices determined defective due to workmanship. No responsibility is assumed for possible omissions and inaccuracies. Circuitry and specifications are subject to change without notice. For the latest product specifications refer to the **Supertex inc.** (website: <http://www.supertex.com>)