

Product Summary Sheet

Applications:

- ▶ Automotive LED Lighting
 - Head Lamps
 - Fog Lamps
 - Tail Light Assemblies
 - Side Marker Lights
 - Interior/Cabin Lighting



8-Lead SOIC (LG)

AT9933 Hysteretic Boost-Buck (Ćuk) LED Driver IC

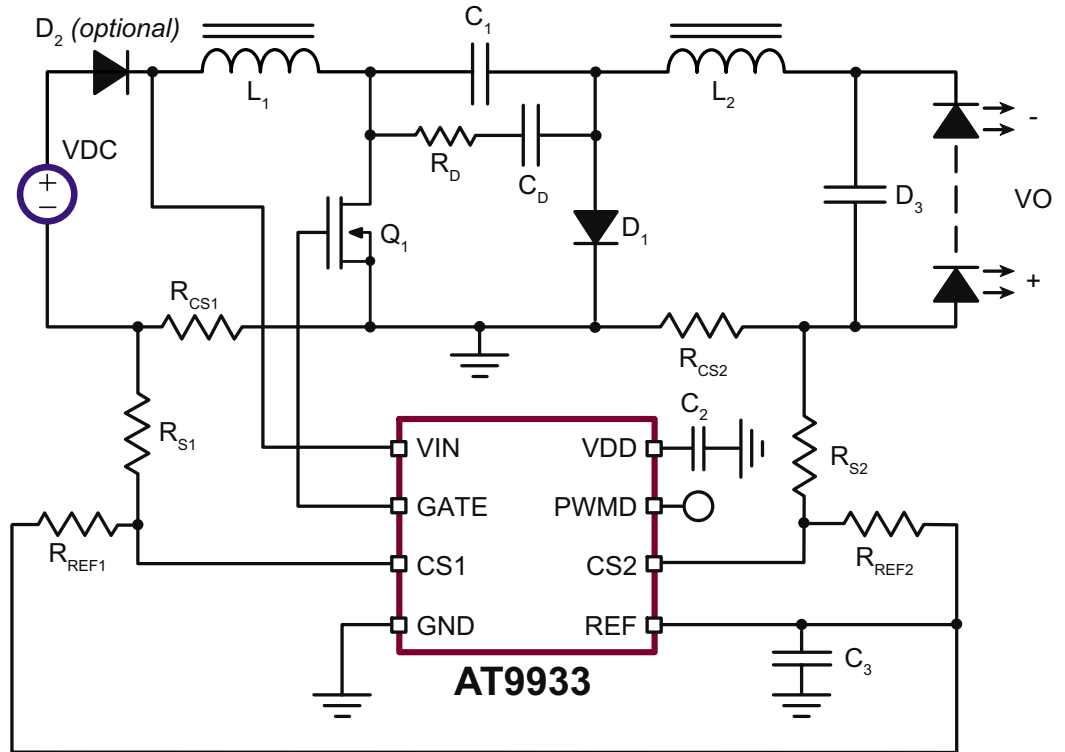

Typical Application Circuit

Product Overview:

The AT9933 is a variable frequency PWM controller IC, designed to control an LED lamp driver using a low-noise boost-buck (Ćuk) topology. The AT9933 uses patent-pending hysteretic current-mode control to regulate both the input and the output currents. This enables superior input surge immunity without the necessity for complex loop compensation. Input current control enables current limiting during startup, input under-voltage and output overload conditions. The AT9933 provides a low-frequency PWM dimming input that can accept an external control signal with a duty cycle of 0 - 100% and a high dimming ratio.

The AT9933 based LED driver is ideal for automotive LED lamps. The part is rated for up to 125°C ambient temperatures and is AEC-Q100-Compliant.

Features:	Benefits:
AEC-Q100-Compliant	Ideal for automotive lighting applications
Hysteretic Control	Simple Low external part count No compensation components Fast transient response and superior surge immunity
Boost-Buck Topology (Ćuk Converter)	Automatic step up or down of input voltage Inherent low EMI Capacitive isolation between input and output to faults
Input and Output Current Sensing	Surge immunity Inherent output short-circuit protection Inherent input under-voltage protection



111710

Supertex inc

AT9933

Hysteretic Boost-Buck (Ćuk) LED Driver IC

Ordering Information / Availability

<u>Part Number</u>	<u>Package Option</u>	<u>Samples</u>	<u>Product Availability</u>
AT9933LG-G	8-Lead SOIC (Green)	Now	2nd Quarter 2007

-G indicates the part is RoHS compliant (Green).



Product Contact

For any questions regarding the AT9933 please contact your local area Supertex sales office, or contact the main office in the US at:

Telephone: 800-222-8888
Fax: 408-222-4895
E-mail: mktg@supertex.com
Web site: www.supertex.com

Supertex inc
1235 Bordeaux Drive, Sunnyvale, CA