

High Speed Quad MOSFET Driver

Features

- ▶ 6ns rise and fall time
- ▶ 2.0A peak output source/sink current
- ▶ 1.8 to 5.0V input CMOS compatible
- ▶ Smart Logic threshold
- ▶ Low jitter design
- ▶ Quad matched channels
- ▶ Drives two N and two P-channel MOSFETs
- ▶ Outputs can swing below ground
- ▶ Built-in level translator for negative gate bias
- ▶ Non-inverting gate driver OUTD for easy logic
- ▶ Low inductance quad flat no-lead package
- ▶ Thermally-enhanced package

Applications

- ▶ Ultrasound PN code transmitter
- ▶ Medical ultrasound imaging
- ▶ Piezoelectric transducer drivers
- ▶ Nondestructive evaluation
- ▶ High speed level translator
- ▶ High voltage bipolar pulser

General Description

The Supertex MD1813 is a high-speed quad MOSFET driver. It is designed to drive two N- and two P-channel, high voltage, DMOS FETs for medical ultrasound applications, but may be used in any application that needs a high output current for a capacitive load. The input stage of the MD1813 is a high-speed level translator that is able to operate from logic input signals of 1.8 to 5.0V amplitude. An adaptive threshold circuit is used to set the level translator threshold to the average of the input logic 0 and logic 1 levels. The level translator uses a proprietary circuit, which provides DC coupling together with high-speed operation.

The output stage of the MD1813 has separate power connections, enabling the output signal L and H levels to be chosen independently from the driver supply voltages. As an example, the input logic levels may be 0 and 1.8V, the control logic may be powered by +5.0 and -5.0V, and the output L and H levels may be varied anywhere over the range of -5.0 to +5.0V. The output stage is capable of peak currents of up to ± 2.0 amps, depending on the supply voltages used and load capacitance. The OE pin serves a dual purpose. First, its logic H level is used to compute the threshold voltage level for the channel input level translators. Secondly, when OE is low, the outputs are disabled, with the A output high and the B output low. This assists in properly pre-charging the coupling capacitors that may be used in series in the gate drive circuit of an external PMOS and NMOS. A built-in level shifter is for PMOS gate negative bias driving. It enables the user-defined damping control to generate return-to-zero bipolar output pulses. The MD1813 has a non-inverting driver OUTD for easy logic.

Typical Application Circuit

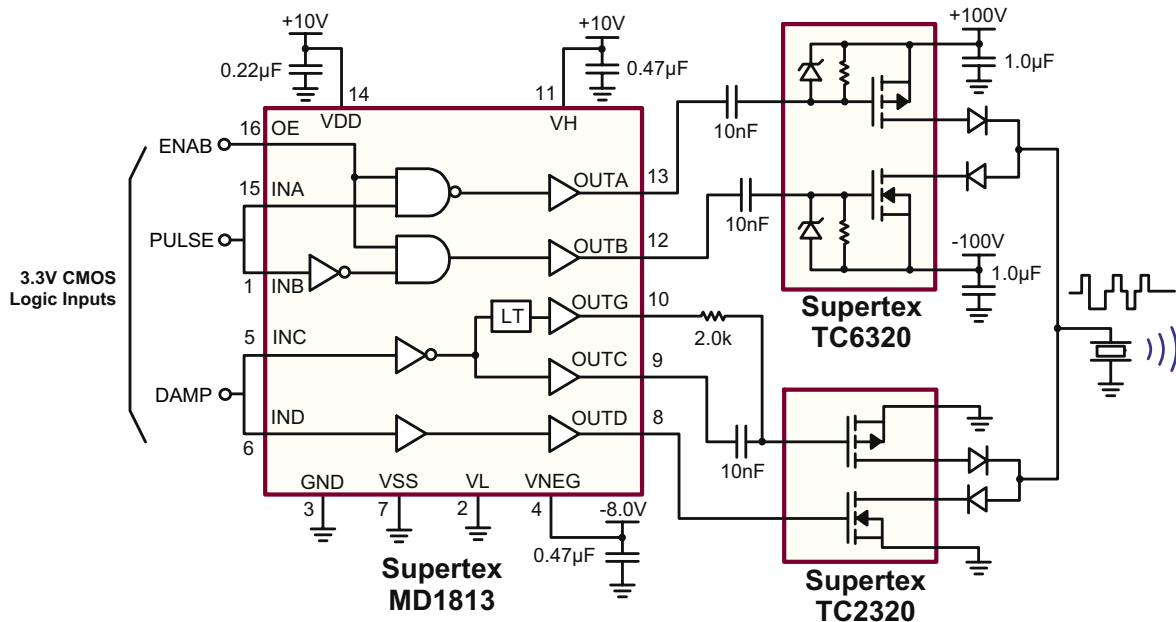

Ordering Information

Device	16-Lead QFN 4.00x4.00mm body 1.00mm height (max) 0.65mm pitch
MD1813	MD1813K6-G

-G indicates package is RoHS compliant ("Green")



Absolute Maximum Ratings

Parameter	Value
$V_{DD}-V_{SS}$, Supply voltage	-0.5V to +13.5V
V_H , Output high supply voltage	V_L -0.5V to V_{DD} +0.5V
V_L , Output low supply voltage	V_{SS} -0.5V to V_H +0.5V
V_{SS} , Low side supply voltage	-7.0V to +0.5V
$V_{DD}-V_{NEG}$, Supply voltage	-0.5V to +20V
$V_{NEG}-V_{SS}$, Negative supply voltage	V_{SS} -10V to V_{SS} +0.5V
Logic input levels	V_{SS} -0.5V to GND +7.0V
Maximum junction temperature	+125°C
Storage temperature	-65°C to 150°C
Operating temperature	-20°C to +85°C
Soldering temperature	235°C
Package power dissipation	2.2W
Thermal resistance (θ_{JA})*	45°C/W

Absolute Maximum Ratings are those values beyond which damage to the device may occur. Functional operation under these conditions is not implied. Continuous operation of the device at the absolute rating level may affect device reliability. All voltages are referenced to device ground.

* 1.0oz 4-layer 3x4" PCB

DC Electrical Characteristics

($V_H = V_{DD} = 12V$, $V_L = V_{SS} = GND = 0V$, $V_{NEG} = -6.0V$, $V_{OE} = 3.3V$, $T_A = 25^\circ C$)

Sym	Parameter	Min	Typ	Max	Units	Conditions
$V_{DD} - V_{SS}$	Supply voltage	4.5	-	13	V	$2.5 \leq V_{DD} \leq 13V$
$V_{DD} - V_{NEG}$	Supply voltage	-	-	18	V	---
V_{SS}	Low side supply voltage	-5.5	-	0	V	---
V_H	Output high supply voltage	$V_{SS} + 2$	-	V_{DD}	V	---
V_L	Output low supply voltage	V_{SS}	-	$V_{DD} - 2$	V	---
V_{NEG}	Negative supply voltage	-9.0	-	$V_{SS} - 2$	V	May connect to VSS if OUTG not used
I_{DDQ}	V_{DD} quiescent current	-	1.5	-	mA	No input transitions, OE = 1
I_{HQ}	V_H quiescent current	-	-	10	μA	
I_{NEGQ}	V_{NEG} quiescent current	-	150	-	μA	
I_{DD}	V_{DD} average current	-	7.0	-	mA	One channel at 5.0Mhz, No load
I_H	V_H average current	-	22	-		
I_{NEG}	V_{NEG} average current	-	1.5	-		

Pin Configuration

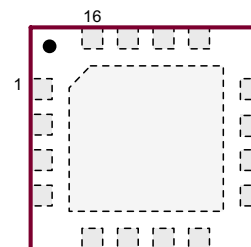

16-Lead QFN (K6)

Product Marking

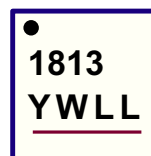

Y = Last Digit of Year Sealed
W = Code for Week Sealed
L = Lot Number
— = "Green" Packaging

Package may or may not include the following marks: Si or

16-Lead QFN (K6)

DC Electrical Characteristics (cont.)

($V_H = V_{DD} = 12V$, $V_L = V_{SS} = GND = 0V$, $V_{NEG} = -6.0V$, $V_{OE} = 3.3V$, $T_A = 25^\circ C$)

Sym	Parameter	Min	Typ	Max	Units	Conditions
V_{IH}	Input logic voltage high	$V_{OE} - 0.3$	-	5.0	V	For logic inputs INA, INB, INC, and IND
V_{IL}	Input logic voltage low	0	-	0.3		
I_{IH}	Input logic current high	-	-	1.0	μA	
I_{IL}	Input logic current low	-	-	1.0		
V_{IH}	OE Input logic voltage high	1.7	-	5.0	V	For logic input OE
V_{IL}	OE Input logic voltage low	0	-	0.3		
R_{IN}	Input logic impedance to GND	10	20	30	K Ω	
C_{IN}	Logic input capacitance	-	5.0	10	pF	---

AC Electrical Characteristics

($V_H = V_{DD} = 12V$, $V_L = V_{SS} = GND = 0V$, $V_{NEG} = -6.0V$, $V_{OE} = 3.3V$, $T_A = 25^\circ C$)

Sym	Parameter	Min	Typ	Max	Units	Conditions
t_{iff}	Input or OE rise & fall time	-	-	10	ns	Logic input edge speed requirement
t_{PLH}	Propagation delay when output is from low to high for OUTA-D	-	7.0	-	ns	$C_{LOAD} = 1000pF$, see timing diagram Input signal rise/fall time 2ns * No load
t_{PHL}	Propagation delay when output is from high to low for OUTA-D	-	7.0	-		
t_{PCG}	Propagation delay INC to OUTG*	-	40	-		
t_r	Output rise time for OUTA-D	-	6.0	-		
t_f	Output fall time for OUTA-D	-	6.0	-		
$ t_r - t_f $	Rise and fall time matching	-	1.0	-	ns	for each channel
$ t_{PLH} - t_{PHL} $	Propagation low to high and high to low matching	-	1.0	-		
Δt_{dm}	Propagation delay matching	-	± 2.0	-	ns	Device to device delay match
t_{OE_OFF}	Output enable time	-	9.0	-	ns	---

Outputs

($V_H = V_{DD} = 12V$, $V_L = V_{SS} = GND = 0V$, $V_{NEG} = -6.0V$, $V_{OE} = 3.3V$, $T_A = 25^\circ C$)

Sym	Parameter	Min	Typ	Max	Units	Conditions
R_{SINK}	Output sink resistance for OUTA-D	-	-	12.5	Ω	$I_{SINK} = 50mA$
R_{SOURCE}	Output source resistance for OUTA-D	-	-	12.5	Ω	$I_{SOURCE} = 50mA$
R_{SINK}	Output sink resistance for for OUTG	-	-	200	Ω	$I_{SINK} = 5.0mA$
R_{SOURCE}	Output source resistance for OUTG	-	-	200	Ω	$I_{SOURCE} = 5.0mA$
I_{SINK}	Peak output sink current	-	2.0	-	A	---
I_{SOURCE}	Peak output source current	-	2.0	-	A	---

Application Information

For proper operation of the MD1813, low inductance bypass capacitors should be used on the various supply pins. The GND pin should be connected to the logic ground. The INA, INB, INC, IND and OE pins should be connected to a logic source with a swing of GND to VCC, where VCC is 1.8 to 5.0 volts. Good trace practices should be followed corresponding to the desired operating speed. The internal circuitry of the MD1813 is capable of operating up to 100MHz, with the primary speed limitation being the loading effects of the load capacitance. Because of this speed and the high transient currents that result with capacitive loads, the bypass capacitors should be as close to the chip pins as possible. Unless the load specifically requires bipolar drive, the VSS, and VL pins should have low inductance feed-through connections directly to a ground plane. If these voltages are not zero, then they need bypass capacitors in a manner similar to the positive power supplies. The power connections VDD should have a ceramic bypass capacitor to the ground plane with short leads and decoupling components to prevent resonance in the power leads.

Output drivers, OUTA and OUTC, drive the gate of an external P-channel MOSFET, while output drivers OUTB and OUTD drive the gate of an external N-channel MOSFET, and they all swing from VH to VL. The auxiliary output drive, OUTG, swings from VSS to VNEG, and drives the external P-channel MOSFET as negative bias via a 2K Ω series resistor.

The voltages of VH and VL decide the output signal levels. These two pins can draw fast transient currents of up to 2.0A, so they should be provided with an appropriate bypass capacitor located next to the chip pins. A ceramic capacitor of up to 1.0 μ F may be appropriate, with a series ferrite bead

to prevent resonance in the power supply lead coming to the capacitor. Pay particular attention to minimizing trace lengths, current loop area, and using sufficient trace width to reduce inductance. Surface mount components are highly recommended. Since the output impedance of this driver is very low, in some cases it may be desirable to add a small series resistance in series with the output signal to obtain better waveform transitions at the load terminals. This will of course reduce the output voltage slew rate at the terminals of a capacitive load.

The OE pin sets the threshold level of logic for inputs ($V_{OE} + V_{GND}$) / 2. When OE is low, OUTA is at VH. OUTB is at VL, regardless of the inputs INA or INB. This pin will not control OUTC, OUTD, or OUTG.

Pay particular attention that parasitic couplings are minimized from the output to the input signal terminals. The parasitic feedback may cause oscillations or spurious waveform shapes on the edges of signal transitions. Since the input operates with signals down to 1.8V, even small coupled voltages may cause problems. Use of a solid ground plane and good power and signal layout practices will prevent this problem. Be careful that a circulating ground return current from a capacitive load cannot react with common inductance to cause noise voltages in the input logic circuitry. Best timing performance is obtained for OUTC when the voltage of ($V_{SS} - V_{NEG}$) = ($V_H - V_L$).

When input logic is high, output will swing to VL, and when input logic is low, output will swing to VH. All inputs must be kept low until the device is powered up.

Timing Diagram and V_{TH} / V_{OE} Curve

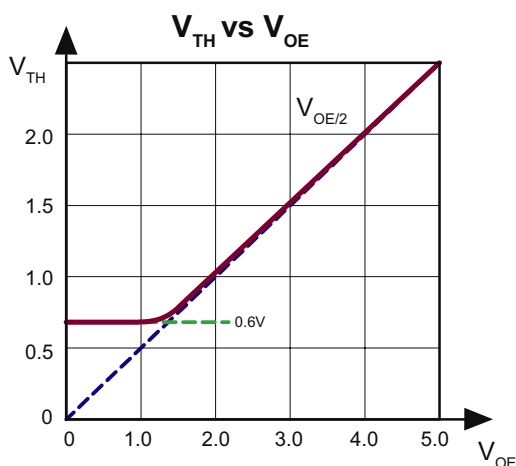
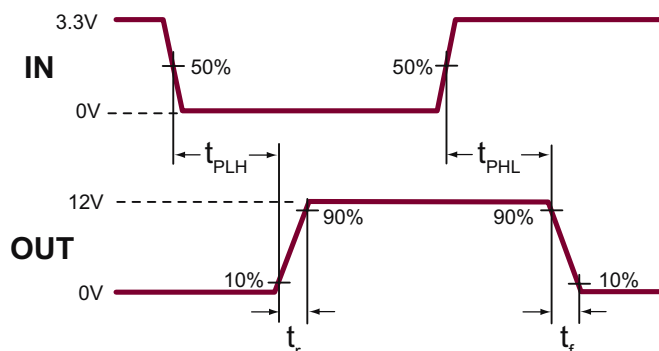

Logic Truth Table

Logic Inputs			Output		
OE	INA	INB	OUTA	OUTB	
H	L	L	V_H	V_H	
H	L	H	V_H	V_L	
H	H	L	V_L	V_H	
H	H	H	V_L	V_L	
L	X	X	V_H	V_L	
OE*	INC	IND	OUTC	OUTG	OUTD**
-	L	L	V_H	V_{SS}	V_L
-	L	H	V_H	V_{SS}	V_H
-	H	L	V_L	V_{NEG}	V_L
-	H	H	V_L	V_{NEG}	V_H

Notes:

* No control to OUTG, OUTC, or OUTD,

** OUTD is non-inverting output

Pin Description

Pin #	Function	Description
1	INB	Logic input. Controls OUTB when OE is high.
2	VL	Supply voltage for N-channel output stage.
3	GND	Device ground.
4	VNEG	Supply voltage the auxiliary gate drive.
5	INC	Logic input. Controls OUTC when OE is high.
6	IND	Logic input. Controls OUTD when OE is high.
7	VSS	Supply voltage for low-side analog, level shifter, and gate drive circuit.
8	OUTD	Output driver.
9	OUTC	Output driver.
10	OUTG	Auxiliary output driver.
11	VH	Supply voltage for P-channel output stage
12	OUTB	Output driver.
13	OUTA	Output driver.
14	VDD	Supply voltage for high-side analog, level shifter, and gate drive circuit.
15	INA	Logic input. Controls OUTA when OE is high.
16	OE	Output enable logic input.

Note:

Thermal pad and pin #4, VNEG must be connected externally.

16-Lead QFN Package Outline (K6)

4.00x4.00mm body, 1.00mm height (max), 0.65mm pitch

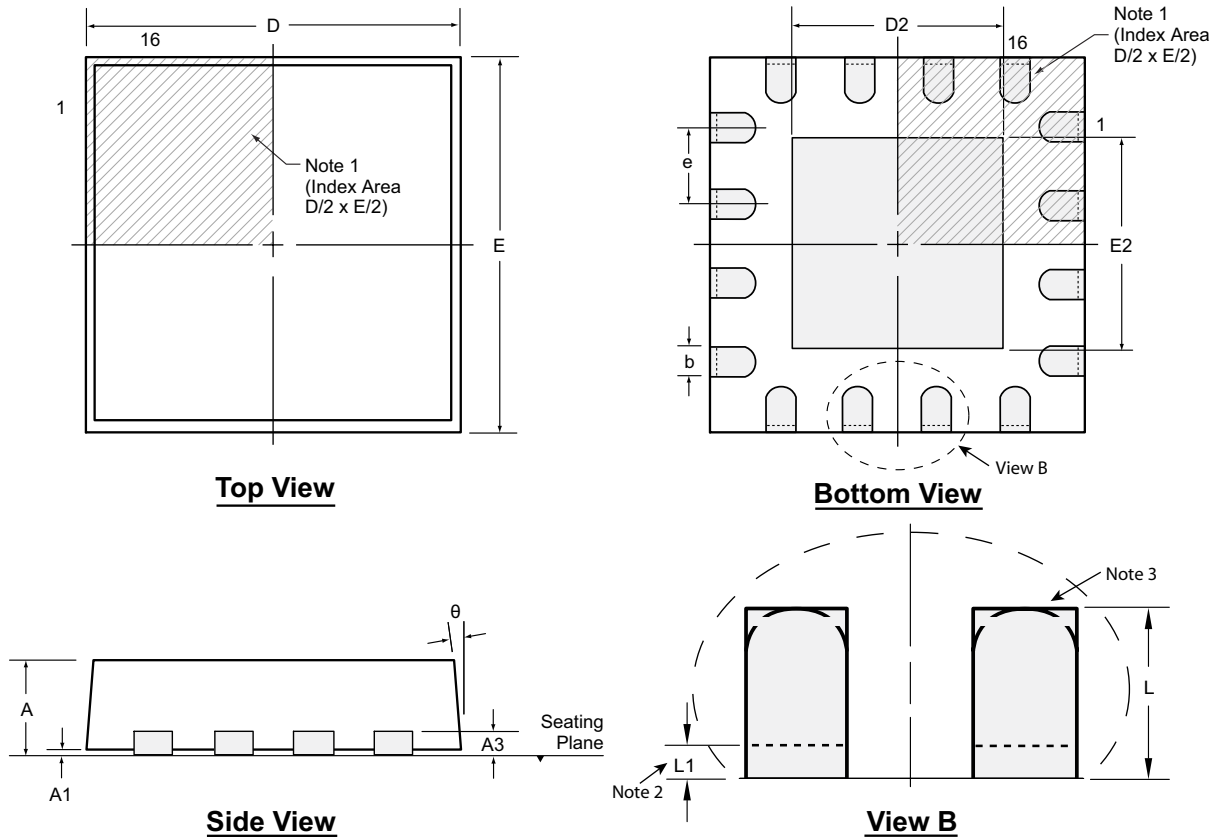

Notes:

1. A Pin 1 identifier must be located in the index area indicated. The Pin 1 identifier can be: a molded mark/identifier; an embedded metal marker; or a printed indicator.
2. Depending on the method of manufacturing, a maximum of 0.15mm pullback (L1) may be present.
3. The inner tip of the lead may be either rounded or square.

Symbol		A	A1	A3	b	D	D2	E	E2	e	L	L1	θ
Dimension (mm)	MIN	0.80	0.00	0.20 REF	0.25	3.85*	2.50	3.85*	2.50	0.65 BSC	0.30†	0.00	0°
	NOM	0.90	0.02		0.30	4.00	2.65	4.00	2.65		0.40†	-	-
	MAX	1.00	0.05		0.35	4.15*	2.80	4.15*	2.80		0.50†	0.15	14°

JEDEC Registration MO-220, Variation VGGC-2, Issue K, June 2006.

* This dimension is not specified in the JEDEC drawing.

† This dimension differs from the JEDEC drawing.

Drawings not to scale.

Supertex Doc.#: DSPD-16QFNK64X4P065, Version C041009.

(The package drawing(s) in this data sheet may not reflect the most current specifications. For the latest package outline information go to <http://www.supertex.com/packaging.html>.)

Supertex inc. does not recommend the use of its products in life support applications, and will not knowingly sell them for use in such applications unless it receives an adequate "product liability indemnification insurance agreement." Supertex inc. does not assume responsibility for use of devices described, and limits its liability to the replacement of the devices determined defective due to workmanship. No responsibility is assumed for possible omissions and inaccuracies. Circuitry and specifications are subject to change without notice. For the latest product specifications refer to the Supertex inc. (website: <http://www.supertex.com>)