

## Liquid Lens Driver

### Features

- ▶ Drives capacitive loads up to 200pF
- ▶ Programmable drive amplitude (up to  $60V_{RMS}$ )
- ▶ On-chip boost converter
- ▶ No external inductor
- ▶ I<sup>2</sup>C interface
- ▶ Low operating current ( $\leq 20mA$ )
- ▶ Low standby current ( $\leq 1.0\mu A$ )
- ▶ Controlled drive edge reduces EMI
- ▶ 1.0mm × 6.0mm flip-chip

### Applications

- ▶ Cell phone and PDA cameras
- ▶ Bar code readers
- ▶ Web and laptop cameras
- ▶ Biometric scanners
- ▶ Ultracompact cameras

### General Description

The HV895 is designed to drive liquid lenses of up to 200pF with a 1.5kHz waveform at amplitudes up to  $60V_{RMS}$ , controlled via an I<sup>2</sup>C interface.

A single byte (AMP) written to the HV895 controls the operation of the driver. Setting AMP = 01h to FFh controls output amplitude in 255 monotonic steps. Setting AMP = 00h causes the HV895 to go into low power standby mode, consuming less than 1.0 $\mu A$ . When active, the HV895 draws less than 20mA.

A charge pump boost converter integrated on-chip provides the high voltage necessary for driving the lens. No external inductors or diodes are needed. Two ceramic 0402 size capacitors are the only external components required for a complete lens driver circuit. The narrow die size and only 2 small external components allow an entire lens driver circuit to be incorporated inside a camera module.

An H-bridge output stage provides AC drive to the lens, allowing the use of a single high voltage boost converter while providing alternating polarity to the lens. Controlled rising and falling edges on the drive waveform reduces EMI.

The HV895 is offered in a 1.0mm × 6.0mm lead-free solder-bumped flip-chip.

### Typical Application Circuit

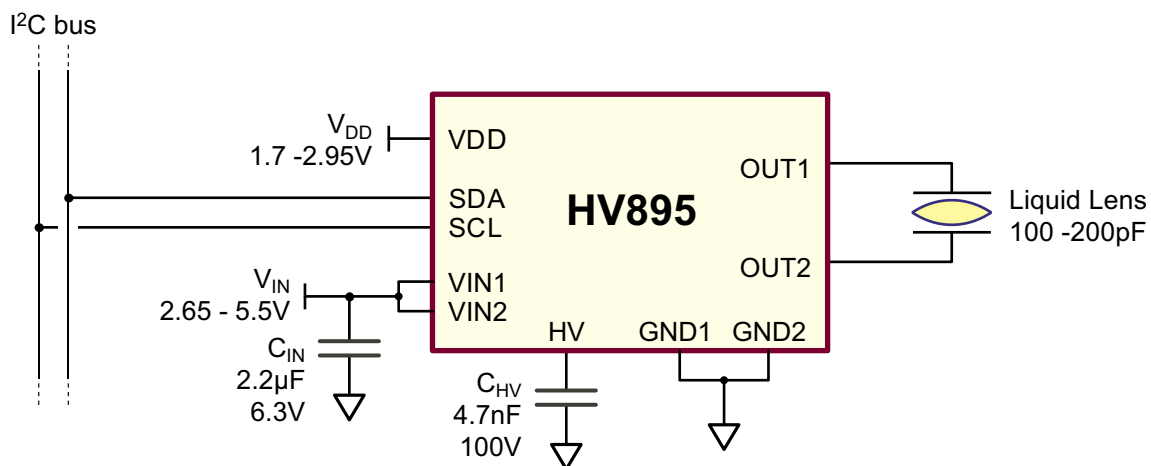

## Ordering Information

Device	Die Option
HV895BD	Lead-free solder-bumped die

This product is RoHS compliant ("Green")



## Ball Configuration

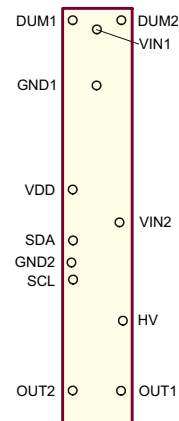

Solder-bumped Die  
(bottom view)

## Absolute Maximum Ratings

Parameter	Value
$V_{IN}, V_{DD}$	-0.5V to 6.5V
SDA, SCL	-0.5V to 6.5V
Operating temperature	-40°C to +85°C
Storage temperature	-65°C to +150°C

Device may not meet specifications, but will incur no damage.

## Product Marking

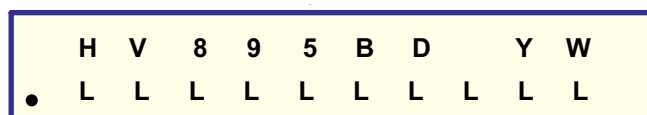

Orientation mark

Y = Year  
W = Week  
L = Lot Number

Solder-bumped Die  
(top view)

## Recommended Operating Conditions

Sym	Parameter	Min	Typ	Max	Units	Conditions
$V_{IN}$	Supply voltage	2.65	-	5.5	V	---
$V_{DD}$	I <sup>2</sup> C logic level reference	1.70	-	2.95	V	---
$t_{VIN}$	Time for $V_{IN}$ to ramp to 90% <sup>(1)</sup>	-	-	2.0	ms	---
$C_{IN}$	Supply bypass capacitor	-	2.2	-	μF	---
$C_{HV}$	High voltage storage capacitor	24	-	-	x $C_{LOAD}$	100V rating
$C_{LOAD}$	Load (lens) capacitance	100	150	200	pF	---
$f_{SCL}$	I <sup>2</sup> C clock	-	-	400	kHz	---
$T_A$	Ambient temperature	-25	-	+85	°C	---

Notes:

- To assure the driver powers up in standby state. No damage will occur if ramped up slower.

## Electrical Specifications (Over recommended operating conditions @ 25°C unless otherwise specified)

Sym	Parameter	Min	Typ	Max	Units	Conditions
$I_{IN}$	$V_{IN}$ supply current	-	- 8.0	500 20	nA mA	AMP = 00h, SDA = $V_{DD}$ , SCL = $V_{DD}$ AMP = FFh, SDA = $V_{DD}$ , SCL = $V_{DD}$
$I_{DD}$	$V_{DD}$ supply current	-	- 9.0	500 12	nA μA	AMP = 00h, SDA = $V_{DD}$ , SCL = $V_{DD}$ AMP = FFh, SDA = $V_{DD}$ , SCL = $V_{DD}$
HV	Output voltage of internal boost converter	71	75	79	V	$C_{LOAD} = 0pF$

## Electrical Specifications *(cont.) (Over recommended operating conditions @ 25°C unless otherwise specified)*

Sym	Parameter	Min	Typ	Max	Units	Conditions
$V_{OUT(AC)}$	AC output voltage	- 9.0 55.0	0 9.6 59.7	- 10.0 62.7	$V_{RMS}$	AMP = 00h AMP = 01h AMP = FFh
$V_{OUT(DC)}$	DC output offset voltage	-2.0	0	+2.0	V	---
DNL	Differential non-linearity (guaranteed monotonic)	-0.5	-	+0.5	LSB	---
$f_{OUT}$	Output frequency	1.0	1.5	2.0	kHz	---
$D_X$	Transition time (fraction of period)	-	4.7	-	%	---
dV/dt	Output slope	-	4.7	-	V/ $\mu$ s	$C_{LOAD} = 150pF, V_{IN} = 3.8V$
$t_{SU}$	Startup time to 90% amplitude <sup>1</sup>	-	-	20	ms	AMP = 00h $\rightarrow$ FFh, $C_{HV} = 4.7nF$
$t_A$	Amplitude response time <sup>1</sup>	-	-	5.0	ms	Over any 1-step AMP increment or decrement (except 00h)
$V_{IL}$	Logic low input voltage	-	-	0.30	$\times V_{DD}$	---
$V_{IH}$	Logic high input voltage	0.7	-	-	$\times V_{DD}$	---
$V_{OL}$	Logic low output voltage	-	-	0.2	$\times V_{DD}$	$I_{LOAD} = 3.0mA$
$I_L$	Logic low input current	-	-	10	$\mu A$	$V_{DD} = 1.70 - 2.95V$
$I_H$	Logic high input current	-	-	10	$\mu A$	$V_{DD} = 1.70 - 2.95V$
$C_{LI}$	Logic input capacitance	-	-	10	pF	$V_{DD} = 1.70 - 2.95V$ , grounded or open

**Notes:**

1. Measured from the rising edge of the I<sup>2</sup>C acknowledge bit that terminates transmission of the AMP data byte.

## Block Diagram and Typical Application

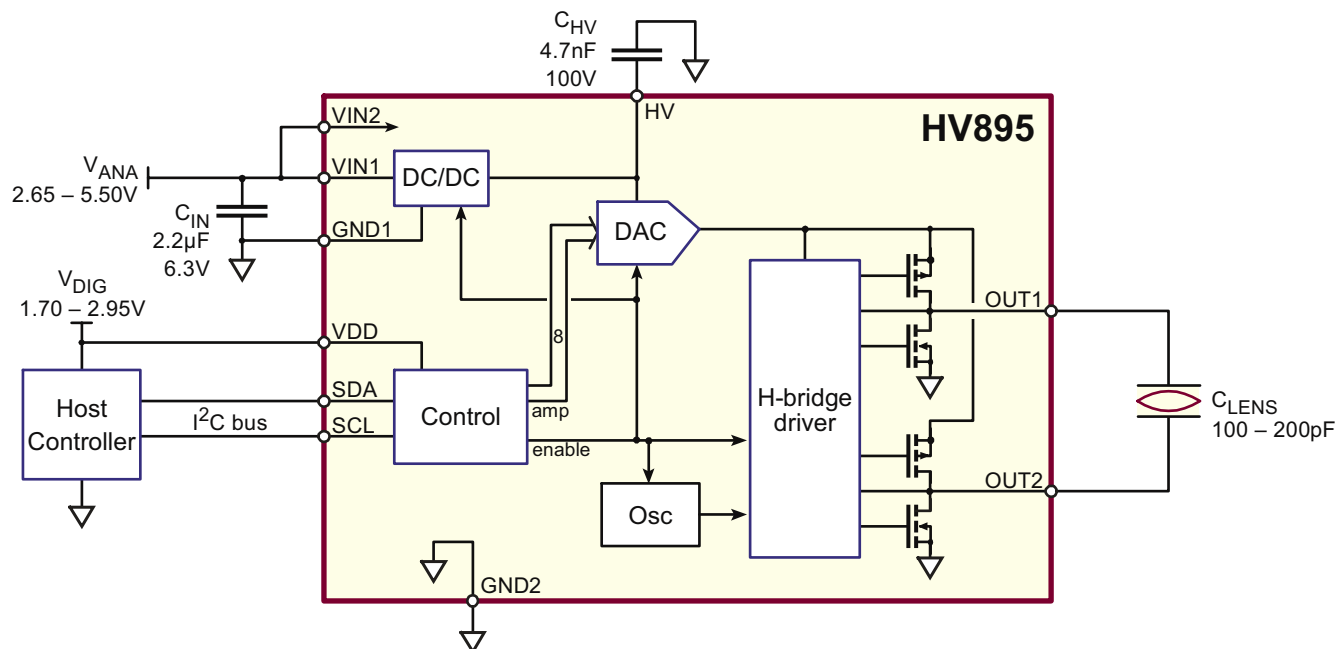

## Output Waveform

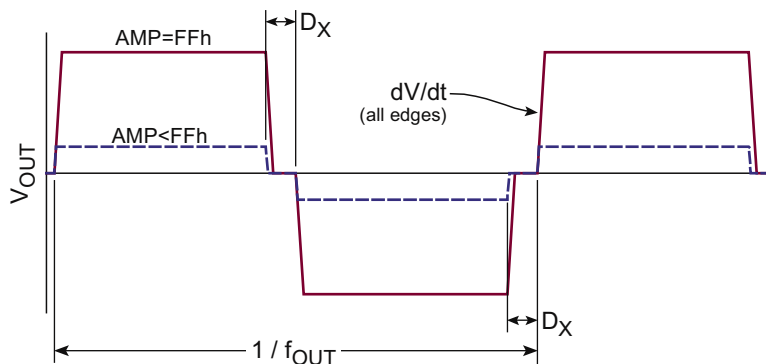

## Applications Information

### I<sup>2</sup>C

The HV895 is a write-only fast mode I<sup>2</sup>C device. Logic voltages are referenced to \$V\_{DD}\$.

### Address

The HV895 recognizes a 7-bit address. The device is pre-programmed with an I<sup>2</sup>C address of 0100011b. For other addresses, please contact the factory.

### Data

A single byte written to the HV895 controls the operation of the lens driver. See the Command Table below. The MSB is clocked-in first.

## Command Table

AMP	Description
00h	Low power standby mode. When in standby mode, the internal boost converter and H-bridge oscillator are shut down, and the OUT pins are held at ground.  Any AMP value other than 00h brings the HV895 out of standby mode. The time it takes the HV895 to exit standby mode and achieve full output amplitude is less than 20ms with a 4.7nF capacitor on the HV pin. Faster startup times may be achieved by lowering \$C_{HV}\$ at the expense of possible waveform distortion.
01h-FFh	Controls output amplitude according to:  $V_{OUT(RMS)} = 9.4V_{RMS} + (AMP \cdot 197mV_{RMS})$ where AMP is an integer from 1 to 255

## Supplies

\$V\_{IN}\$ must be ramped up in less than 2.0ms to assure the driver starts-up in standby mode. If brought up slower, the driver may not start-up in standby mode, with output amplitude at an indeterminate level. In this case, writing AMP = 00h brings the driver to standby mode. No damage will occur if ramped slower than 2.0ms.

## Die Dimensions

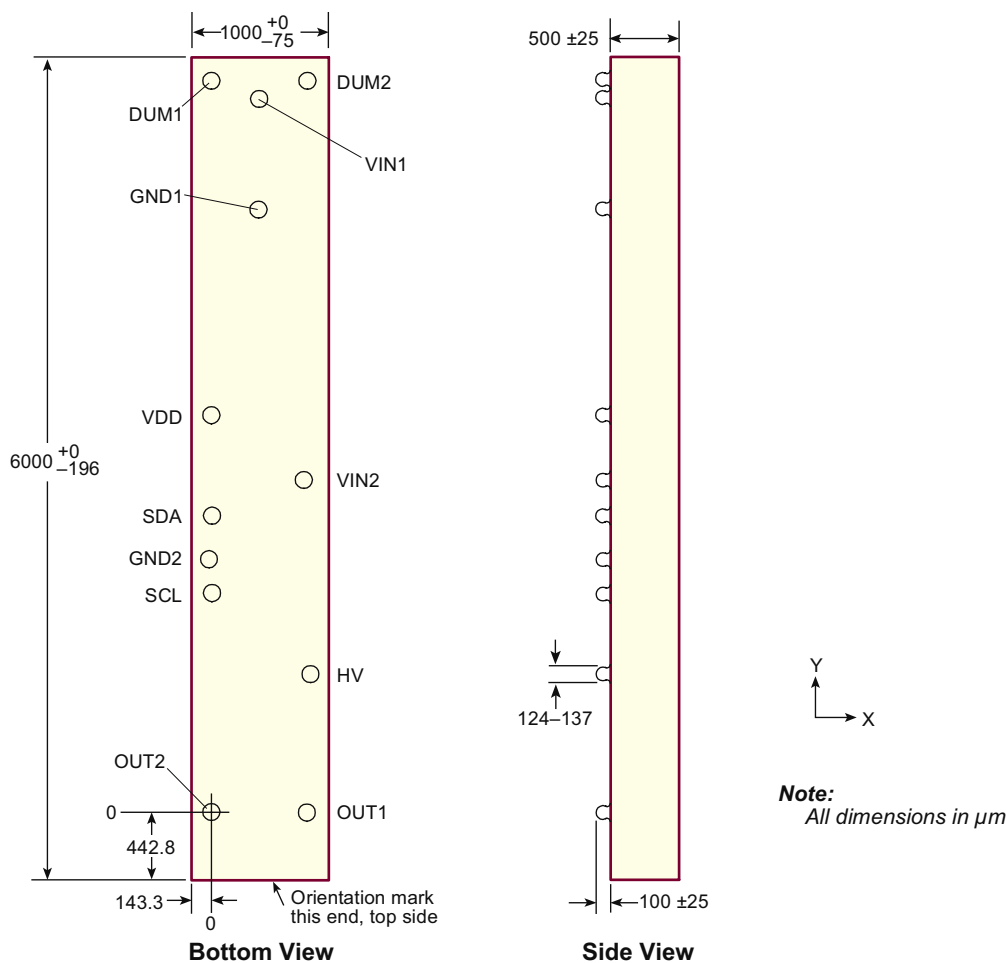

## Bump Coordinates and Descriptions (XY coordinates reference center of bump and are in $\mu\text{m}$ . Tolerance is $\pm 15\mu\text{m}$ .)

Bump	X	Y	Description
VIN1	353.4	5201.7	VIN1 supplies the DC-DC converter. VIN2 supplies the rest of the IC. They must be tied together. To minimize conducted EMI, bypass with a 2.2 $\mu\text{F}$ ceramic capacitor to ground close to the IC.
VIN2	675.4	2424.6	
VDD	12.7	2891.0	Externally supplied reference voltage for the I <sup>2</sup> C logic levels. Connect to the I <sup>2</sup> C bus supply.
GND1	353.4	4397.6	GND1 is the ground for the for the DC-DC converter, while GND2 is for the rest of the IC. Connect both to system ground.
GND2	-14.8	1844.0	
SCL	12.7	1594.0	Serial clock for the I <sup>2</sup> C interface. The HV895 is a Fast Mode device ( $f_{\text{SCL}} \leq 400\text{kHz}$ ).
SDA	12.7	2171.2	Serial data for the I <sup>2</sup> C interface. The HV895 is a write-only device, with a single 8-bit command byte (AMP, see page 4).
HV	722.4	1006.6	High voltage DC output of the internal boost converter. Connect a 4.7nF, 100V ceramic capacitor to ground close to the IC.
OUT1	666.3	0.0	Outputs of the H-bridge driver. The liquid lens connects between these two bumps. When disabled (AMP = 00h), both of these outputs are held at ground.
OUT2	0	0	
DUM1	3.9	5334.2	These bumps are for mechanical support only. Provide pads on the PCB for these solder bumps. No electrical connections should be made to these bumps.
DUM2	702.9	5334.2	

Supertex inc. does not recommend the use of its products in life support applications, and will not knowingly sell them for use in such applications unless it receives an adequate "product liability indemnification insurance agreement." Supertex inc. does not assume responsibility for use of devices described, and limits its liability to the replacement of the devices determined defective due to workmanship. No responsibility is assumed for possible omissions and inaccuracies. Circuitry and specifications are subject to change without notice. For the latest product specifications refer to the Supertex inc. website: <http://www.supertex.com>.