

## 34-Channel Symmetric Row Driver

### Features

- ▶ HVCMOS® technology
- ▶ Symmetric row drive (reduces latent imaging in ACTFEL displays)
- ▶ Output voltage up to +230V
- ▶ Low power level shifting
- ▶ Source/sink current minimum 70mA
- ▶ Shift register speed 4.0MHz
- ▶ Pin-programmable shift direction

### General Description

The HV7022C is a low-voltage serial to high-voltage parallel converter with push-pull outputs. It is especially suited for use as a symmetric row driver in AC thin-film electroluminescent (ACTFEL) displays. The HV7022C offers 34 output lines, a direction (DIR) pin to give CW or CCW shift register loading, output enable (OE), and polarity (POL) control. After data is entered (on the falling edge of CLK), a logic high will cause the output to swing to VPP if POL is high, or to GND if POL is low.

### Functional Block Diagram

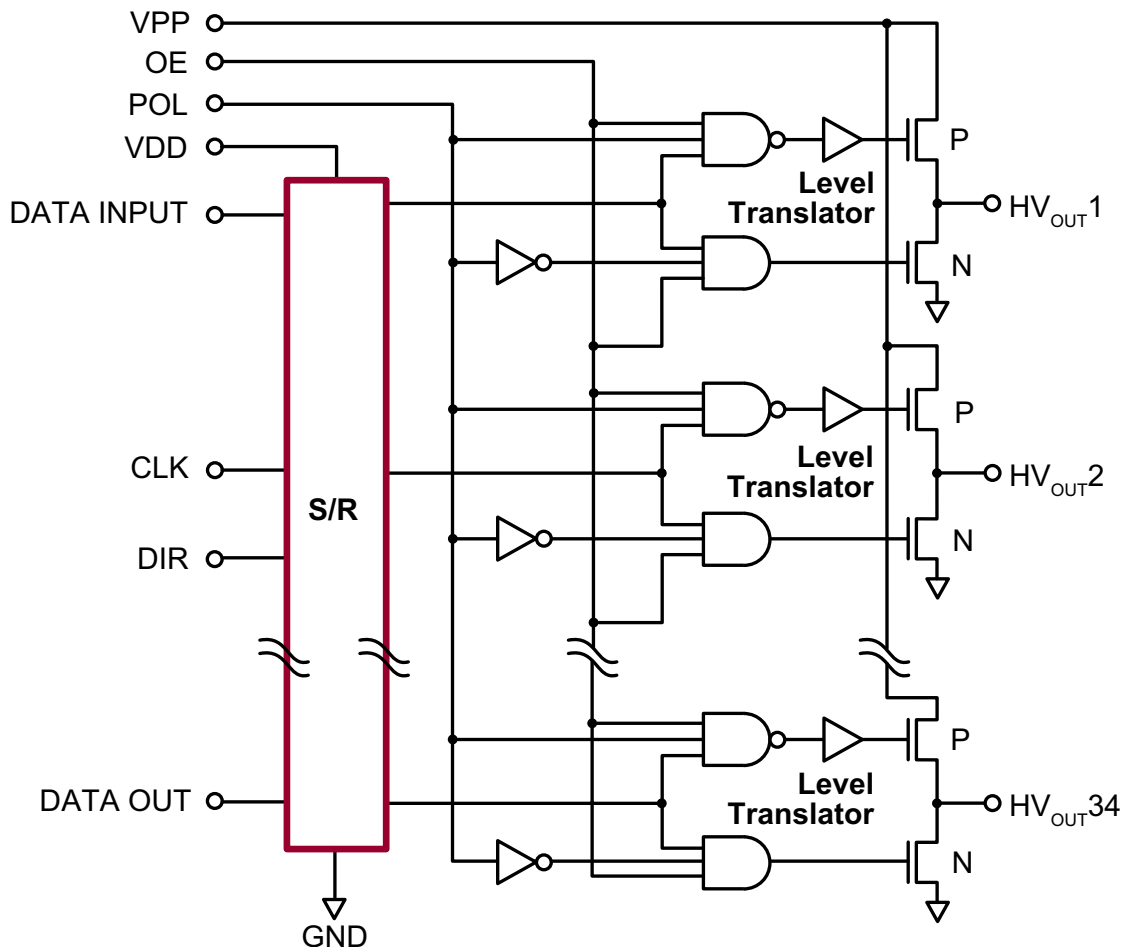

## Ordering Information

Device	Package Options	
	44-Lead Quad Cerpac Chip Carrier .650x.650in body .190in height (max) .050in pitch	44-Lead PLCC .653x.653in body .180in height (max) .050in pitch
HV7022-C	HV7022DJ-C*	HV7022PJ-C-G



-G indicates package is RoHS compliant ("Green")

\* Hi-Rel process flow available.

## Absolute Maximum Ratings

Parameter	Value
Supply voltage, $V_{DD}$	-0.3V to +15V
Supply voltage, $V_{PP}$	-0.3V to +250V
Logic input levels	-0.3V to $V_{DD} + 0.3V$
Ground current <sup>1</sup>	1.5A
Continuous total power dissipation <sup>2</sup>	
Plastic	1200mW
Ceramic	1500mW
Operating temperature range	
Plastic	-40°C to +85°C
Ceramic	-55°C to +125°C
Storage temperature range	-65°C to +150°C

Absolute Maximum Ratings are those values beyond which damage to the device may occur. Functional operation under these conditions is not implied. Continuous operation of the device at the absolute rating level may affect device reliability. All voltages are referenced to device ground.

### Notes:

- Duty cycle is limited by the total power dissipated in the package.
- For operation above 25°C ambient derate linearly to maximum operating temperature at 25mW/°C for plastic and at 15mW/°C for ceramic.

## Pin Configuration

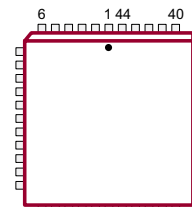

44-Lead Quad Cerpac Chip Carrier (DJ)  
(top view)

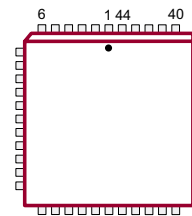

44-Lead PLCC (PJ)  
(top view)

## Product Marking

### Top Marking



YY = Year Sealed  
WW = Week Sealed  
L = Lot Number  
C = Country of Origin\*

### Bottom Marking

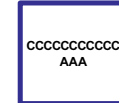

A = Assembler ID\*  
\*May be part of top marking

Package may or may not include the following marks: Si or **44-Lead Quad Cerpac Chip Carrier (DJ)**

### Top Marking



YY = Year Sealed  
WW = Week Sealed  
L = Lot Number  
A = Assembler ID  
C = Country of Origin\*

### Bottom Marking

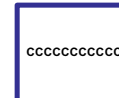

— = "Green" Packaging  
\*May be part of top marking

Package may or may not include the following marks: Si or **44-Lead PLCC (PJ)**

## Recommended Operating Conditions

Sym	Parameter	Min	Max	Units	
$V_{DD}$	Logic supply voltage	10.8	13.2	V	
$V_{PP}$	High voltage supply	-	230	V	
$V_{IH}$	High-level input voltage	$V_{DD} = 10.8$	8.1	-	V
		$V_{DD} = 13.2$	9.9	-	
$V_{IL}$	Low-level input voltage	$V_{DD} = 10.8$	-	2.7	V
		$V_{DD} = 13.2$	-	3.3	
$f_{CLK}$	Clock frequency	-	4.0	MHz	
$T_A$	Operating free-air temperature	Plastic	-40	+85	°C
		Ceramic	-55	+125	
$I_{OD}$	Allowable pulsed current through output diode	-	±300	mA	

**Power-up sequence should be the following:**

1. Connect ground.
  2. Apply  $V_{DD}$ .
  3. Set all inputs (Data, CLK, Enable, etc.) to a known state.
  4. Apply  $V_{PP}$ .
- (The  $V_{PP}$  should not drop below  $V_{DD}$  or float during operation.)

**Power-down sequence should be the reverse of the above.**

## DC Electrical Characteristics (over recommended operating conditions of $V_{DD} = 12V$ , $V_{PP} = 230V$ , and $T_A = 25^\circ C$ unless noted)

Sym	Parameter	Min	Max	Units	Conditions	
$I_{DD}$	$V_{DD}$ supply current	-	10	mA	$f_{CLK} = 4.0MHz$ , $V_{DD} = 13.2V$	
$I_{PP}$	$V_{PP}$ supply current	-	4.0	mA	One output high <sup>1</sup>	
		-	100	µA	All outputs low or High-Z	
		-	750		All outputs low or High-Z (125°C)	
$I_{DDQ}$	Quiescent $V_{DD}$ supply current	-	100	µA	All $V_{IN} = GND$ or $V_{DD}$	
$V_{OH}$	High-level output	HV <sub>OUT</sub>	195	-	V	$I_O = -70mA$
		DATA OUT	11	-	V	$I_O = -500\mu A$
$V_{OL}$	Low-level output	HV <sub>OUT</sub>	-	30	V	$I_O = +70mA$
		DATA OUT	-	1.0	V	$I_O = +500\mu A$
$I_{IH}$	High-level logic input current	-	1.0	µA	$V_{IH} = 12V$	
$I_{IL}$	Low-level logic input current	-	-1.0	µA	$V_{IL} = 0V$	

**Note:**

1. The total number of ON outputs times the duty cycle must not exceed the allowable package power dissipation.

## AC Electrical Characteristics ( $V_{DD} = 12V$ and $T_A = 25^\circ C$ )

Sym	Parameter	Min	Max	Units	Conditions
$f_{CLK}$	Clock frequency	-	4.0	MHz	---
$t_{WH}, t_{WL}$	Pulse duration clock width high or low	125	-	ns	---
$t_{SUD}$	Data set-up time before falling clock	100	-	ns	---
$t_{HD}$	Data hold time after falling clock	100	-	ns	---
$t_{SUC}$	Setup time clock low before $V_{PP}\uparrow$ or GND $\downarrow$	300	-	ns	---
$t_{SUE}$	Setup time enable high before $V_{PP}\uparrow$ or GND $\downarrow$	300	-	ns	---
$t_{SUP}$	Setup time polarity high or low before $V_{PP}\uparrow$ or GND $\downarrow$	300	-	ns	---
$t_{HC}$	Hold time clock high after $V_{PP}\uparrow$ or GND $\downarrow$	500	-	ns	---
$t_{HE}$	Hold time enable high after $V_{PP}\uparrow$ or GND $\downarrow$	300	-	ns	---
$t_{HP}$	Hold time polarity high or low after $V_{PP}\uparrow$ or GND $\downarrow$	300	-	ns	---
$t_{DHL}$	Delay time high to low-level output from clock	-	150	ns	$C_L = 10pF$
$t_{DLH}$	Delay time low to high-level output from clock	-	200	ns	$C_L = 10pF$
$t_{THL}$	Transition time high to low-level serial output	-	200	ns	$C_L = 15pF$
$t_{TLH}$	Transition time low to high-level serial output	-	100	ns	$C_L = 15pF$
$t_{ONH}$	High-level turn-on time $HV_{OUT}$ from enable	-	500	ns	$V_{OH} = 195V, R_L = 2.0k\Omega$ to 95V
$t_{ONL}$	Low-level turn-on time $HV_{OUT}$ from enable	-	500	ns	$V_{OH} = 130V, R_L = 2.0k\Omega$ to 30V
$t_{OFFH}$	High-level turn-off time $HV_{OUT}$ from enable	-	1000	ns	$V_{OH} = 195V, R_L = 2.0k\Omega$ to 95V
$t_{OFFL}$	Low-level turn-off time $HV_{OUT}$ from enable	-	500	ns	$V_{OH} = 130V, R_L = 2.0k\Omega$ to 30V
SR	Slew rate, $V_{PP}$ or GND	-	45	V/ $\mu s$	One active output driving 4.7nF load to $V_{PP}$ or GND

## Function Table

I/O Relations	Inputs					Outputs		
	CLK	DIR	DATA	POL	OE	Shift Reg	$HV_{OUT}$	DATA OUT
O/P HIGH	X	X	H	H	H	*	H	*
O/P OFF	X	X	L	H	H	*	HIGH-Z	*
O/P LOW	X	X	H	L	H	*	L	*
O/P OFF	X	X	L	L	H	*	HIGH-Z	*
O/P OFF	X	X	X	X	L	*	All O/P HIGH-Z	*
Load S/R, set DIR	$\downarrow$	L	X	X	X	$Q_n \rightarrow Q_{n+1}$	*	$Q_{34}$
	$\downarrow$	H	X	X	X	$Q_n \rightarrow Q_{n-1}$	*	$Q_1$
	No $\downarrow$	X	X	X	X	*	No Change	No Change

### Notes:

H = logic high level, L = logic low level, X = irrelevant,  $\downarrow$  = high-to-low transition

$Q1 = HV_{OUT,1}$ ,  $Qn = HV_{OUT,n}$ , etc.

\* = dependent on previous state and whether an O/P or S/R command occurred.

### HV<sub>OUT</sub> Characteristics

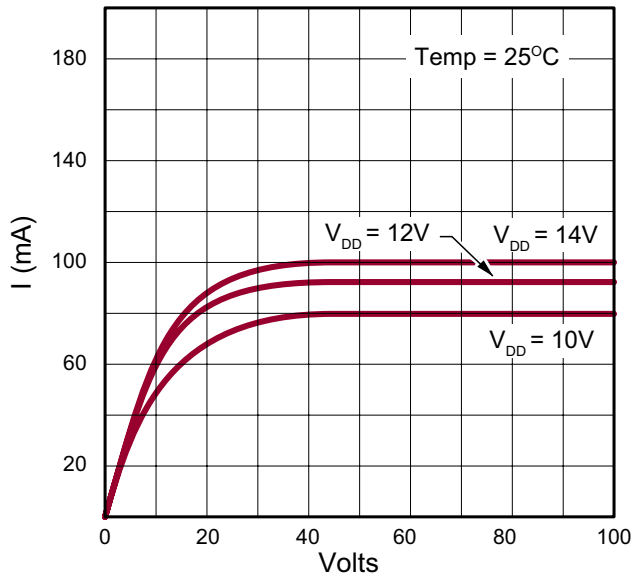

Output N-Channel Characteristics through FET

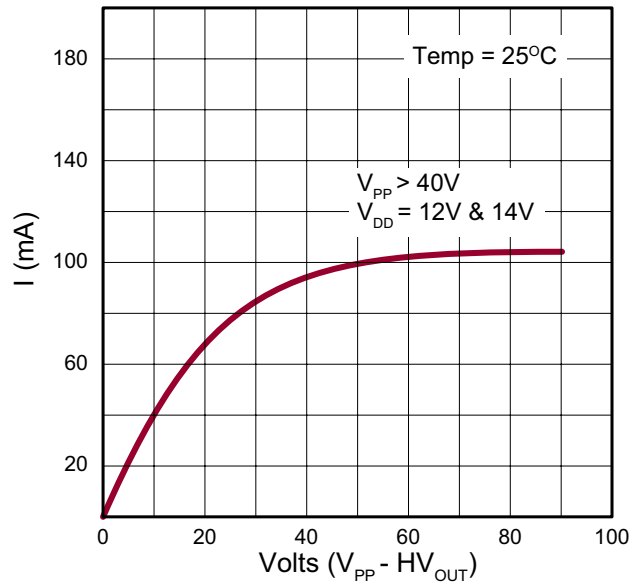

Output P-Channel Characteristics through FET

### Input and Output Equivalent Circuits

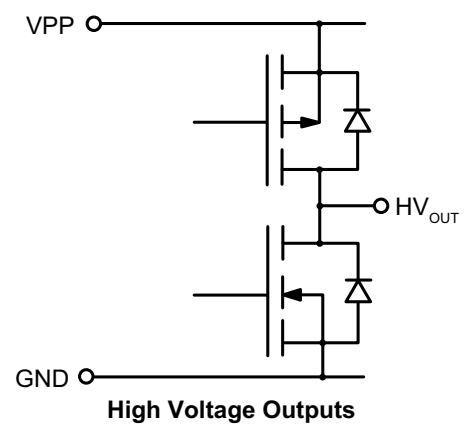
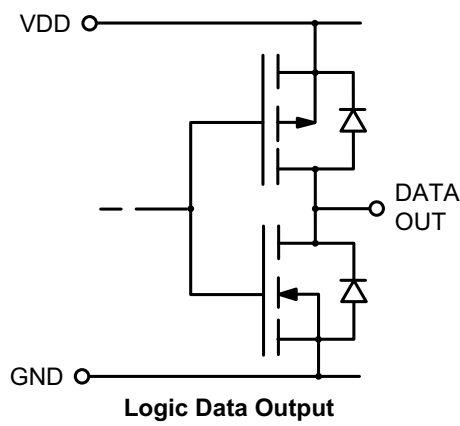
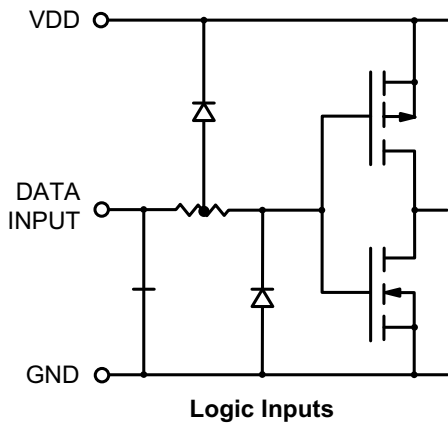

Switching Waveforms

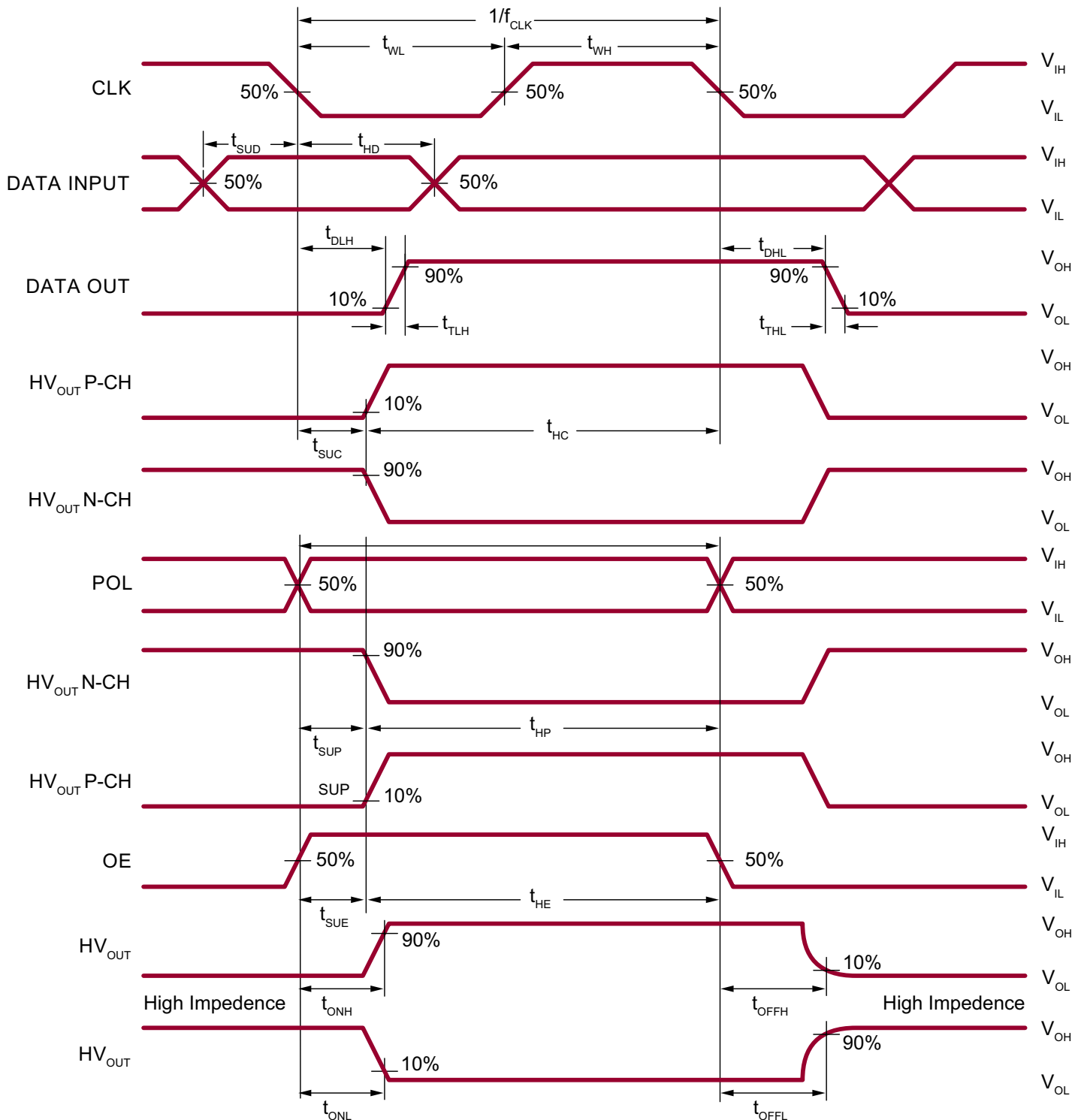

## Pin Descriptions

Pin #	Function
1	HV <sub>OUT</sub> 18/17
2	HV <sub>OUT</sub> 17/18
3	HV <sub>OUT</sub> 16/19
4	HV <sub>OUT</sub> 15/20
5	HV <sub>OUT</sub> 14/21
6	HV <sub>OUT</sub> 13/22
7	HV <sub>OUT</sub> 12/23
8	HV <sub>OUT</sub> 11/24
9	HV <sub>OUT</sub> 10/25
10	HV <sub>OUT</sub> 9/26
11	HV <sub>OUT</sub> 8/27
12	HV <sub>OUT</sub> 7/28
13	HV <sub>OUT</sub> 6/29
14	HV <sub>OUT</sub> 5/30
15	HV <sub>OUT</sub> 4/31
16	HV <sub>OUT</sub> 3/32
17	HV <sub>OUT</sub> 2/33
18	HV <sub>OUT</sub> 1/34
19	DATA OUT
20	OE
21	CLK
22	GND

Pin #	Function
23	DIR
24	VDD
25	POL
26	DATA INPUT
27	VPP
28	NC
29	HV <sub>OUT</sub> 34/1
30	HV <sub>OUT</sub> 33/2
31	HV <sub>OUT</sub> 32/3
32	HV <sub>OUT</sub> 31/4
33	HV <sub>OUT</sub> 30/5
34	HV <sub>OUT</sub> 29/6
35	HV <sub>OUT</sub> 28/7
36	HV <sub>OUT</sub> 27/8
37	HV <sub>OUT</sub> 26/9
38	HV <sub>OUT</sub> 25/10
39	HV <sub>OUT</sub> 24/11
40	HV <sub>OUT</sub> 23/12
41	HV <sub>OUT</sub> 22/13
42	HV <sub>OUT</sub> 21/14
43	HV <sub>OUT</sub> 20/15
44	HV <sub>OUT</sub> 19/16

**Note:**

Pin designation for DIR H/L

Example: For DIR = H, pin 1 is HV<sub>OUT</sub> 18

For DIR = L, pin 1 is HV<sub>OUT</sub> 17

# 44-Lead Quad Cerpac Package Outline (DJ)

.650x.650in body, .190in height (max), .050in pitch

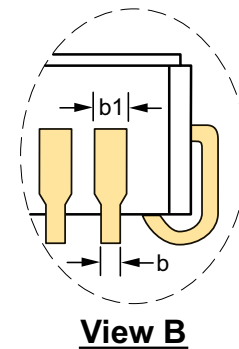
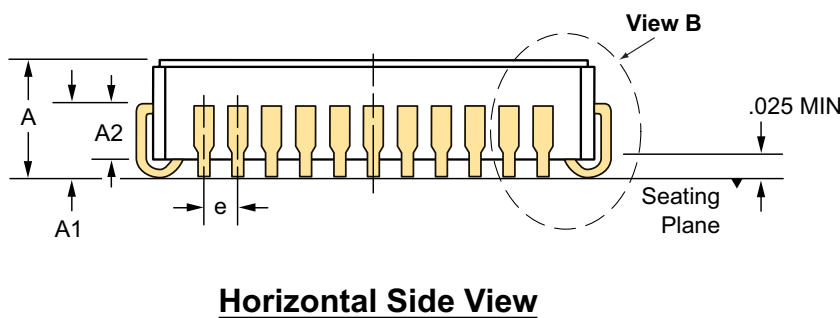
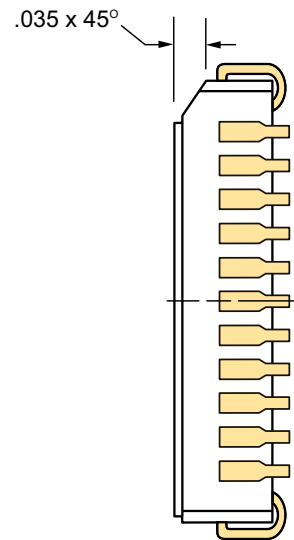
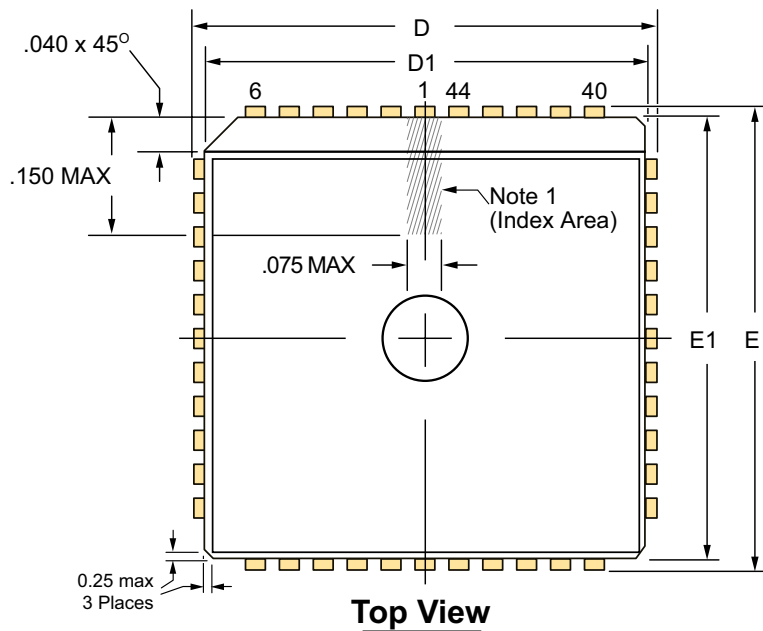

**Note:**  
 1. A Pin 1 identifier must be located in the index area indicated. The Pin 1 identifier can be: a molded mark/identifier; an embedded metal marker; or a printed indicator.

Symbol	A	A1	A2	b	b1	D	D1	E	E1	e	
Dimension (inches)	MIN	.155	.090	.060 REF	.017	.026	.685	.630	.685	.630	.050 BSC
	NOM	.172	.100		.019	.029	.690	.650	.690	.650	
	MAX	.190	.120		.021	.032	.695	.665	.695	.665	

JEDEC Registration MO-087, Variation AB, Issue B, August, 1991.  
 Drawings not to scale.  
 Supertex Doc. #: DSPD-44CERPACDJ, Version D090808.

# 44-Lead PLCC Package Outline (PJ)

.653x.653in body, .180in height (max), .050in pitch

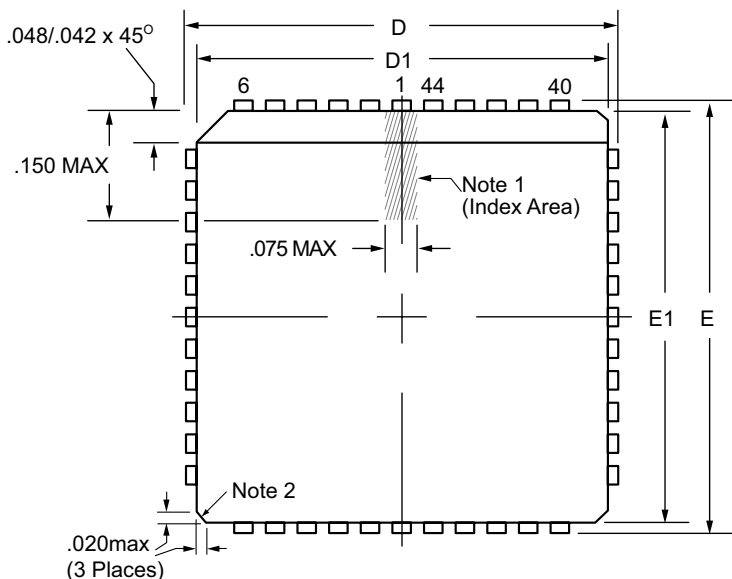

**Top View**

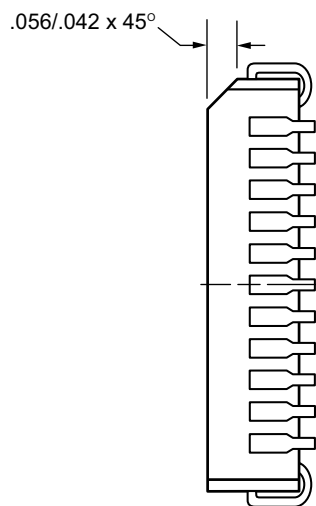

**Vertical Side View**

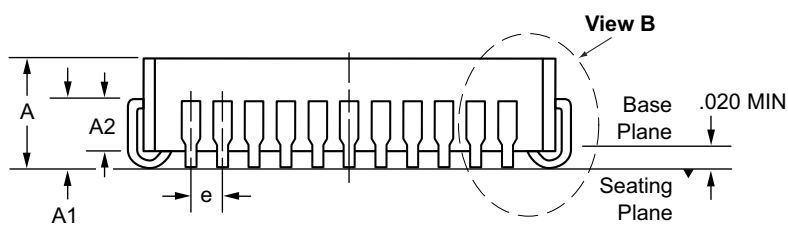

**Horizontal Side View**

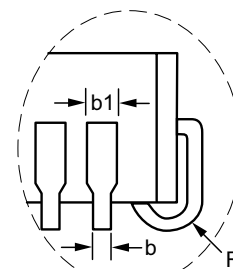

**View B**

**Notes:**

1. A Pin 1 identifier must be located in the index area indicated. The Pin 1 identifier can be: a molded mark/identifier; an embedded metal marker; or a printed indicator.
2. Actual shape of this feature may vary.

Symbol		A	A1	A2	b	b1	D	D1	E	E1	e	R
Dimension (inches)	MIN	.165	.090	.062	.013	.026	.685	.650	.685	.650	.050 BSC	.025
	NOM	.172	.105	-	-	-	.690	.653	.690	.653		.035
	MAX	.180	.120	.083	.021	.036 <sup>†</sup>	.695	.656	.695	.656		.045

JEDEC Registration MS-018, Variation AC, Issue A, June, 1993.

<sup>†</sup> This dimension differs from the JEDEC drawing.

**Drawings not to scale.**

**Supertex Doc. #: DSPD-44PLCCPJ, Version F031111.**

(The package drawing(s) in this data sheet may not reflect the most current specifications. For the latest package outline information go to <http://www.supertex.com/packaging.html>.)

**Supertex inc.** does not recommend the use of its products in life support applications, and will not knowingly sell them for use in such applications unless it receives an adequate "product liability indemnification insurance agreement." **Supertex inc.** does not assume responsibility for use of devices described, and limits its liability to the replacement of the devices determined defective due to workmanship. No responsibility is assumed for possible omissions and inaccuracies. Circuitry and specifications are subject to change without notice. For the latest product specifications refer to the **Supertex inc.** (website: <http://www.supertex.com>)