

HV839 Dual EL Lamp Driver Circuits

Introduction

This Application Note provides example circuits as a guideline for applications with different lamp sizes and input voltages. For additional assistance in designing EL driver circuits, please refer to application notes AN-H33 (effect of external components on performance of Supertex EL drivers) and AN-H43 (This Application Note describes the method to reduce the audible noise generated by the EL lamp for Mobile Phone applications).

When constructing and testing one of the driver circuits listed below, keep in mind that results may differ from those given due to lamp characteristics and also component tolerance.

When making component changes for circuit optimization, always remove the supply voltages first. After making the adjustments, bring up the supply voltage slowly starting from the minimum required device input voltage while monitoring the input current. A sharp rise in current usually indicates a saturated inductor. Use a higher current rated inductor or a higher value inductor.

L_x Inductor Selection:

Different inductor values and/or from different manufacturers can be used in place of what is shown. However, it is very important to make a note that the switching frequency of the device is set via an external resistor and the inductor saturation current shall not be approached by selecting

appropriate R_{SW-OSC} resistor value. If the inductor saturation current is lower than what the circuit/application requires, smaller resistor value will need to be used to increase the inductor switching frequency or the inductor and/or IC will be damaged.

C_s Capacitor Selection:

Different C_s capacitor types and value can be used in place of what is shown above. However, using a different C_s capacitor type will emit audible noise due to piezo electric effect of materials used for their structure (such as X7R, Y5V, ... capacitors).

A different value capacitor can be used. A larger value C_s capacitor (10nF) is recommended to be used for larger EL lamps and/or larger input voltage range. Smaller value C_s capacitors can be used as long as the over all efficiency of the circuit is not decreased.

Larger value capacitors can be used without any significant effect on performance of the circuit.

Other Design Considerations:

Please note that the EL1 and EL2 output are not of the same strength. The EL1 is designed to be able to handle larger loads (EL lamps) than the EL2. Therefore, we recommend using the EL1 for larger lamps to obtain best efficiency.

Typical Application Circuit

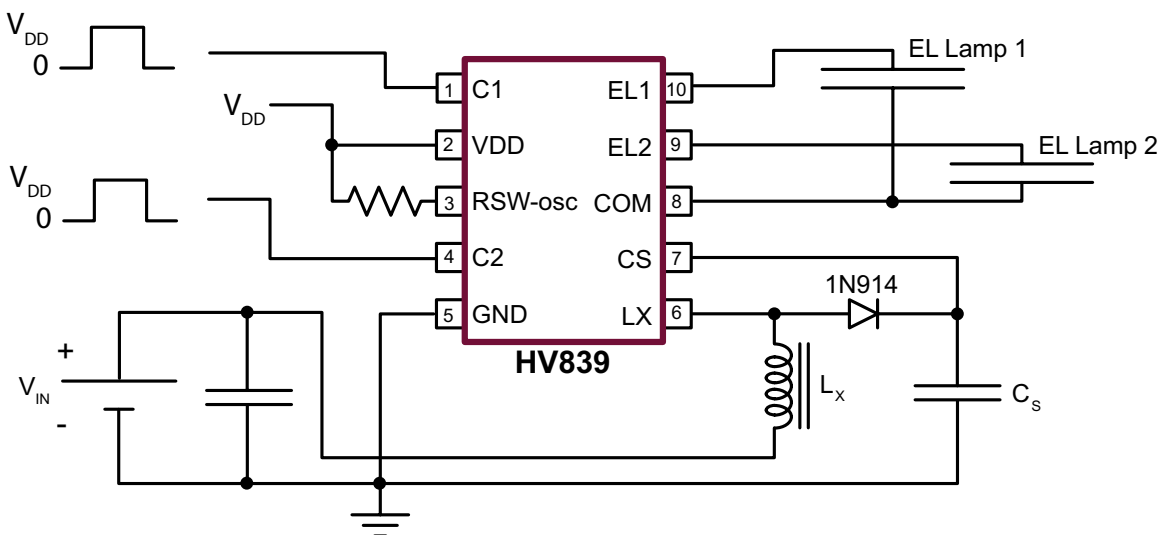

HV839 Circuit Selector Guide

Selecting the R_{SW-OSC} resistor value, where the larger value will provide slower frequency, sets the inductor frequency for the HV839. The lamp frequency is equal to the inductor switching frequency divided by 128.

Circuit	Application	Supply Voltage		Lamp Size		Lamp Selection	I_{IN}^1	V_{CS}	f_{EL}	Lamp Brightness ¹	
		V_{DD} (V)	V_{IN} (V)	EL1 (in ²)	EL2 (in ²)		(mA)	(V)	(Hz)	(ft-lm)	(Cd/m ²)
1	GPSs, cell phones, two-way pagers, MP3 players or any dual display applications organizers, or any Dual display applications	2.8	2.8	0.93	0.60	EL1	19.0	89.0	357	10.35	35.40
						EL2	18.4	89.1		10.35	35.40
						Both	32.9	85.3		10.00	32.40
2		3.0	3.0	1.30	0.93	EL1	25.1	84.5	244	7.09	24.24
						EL2	23.4	84.9		7.47	25.56
						Both	39.4	76.2		6.54	22.38
3		3.0	3.0	0.93	0.93	EL1	14.4	70.6	225	6.05	20.68
						EL2	16.7	70.9		6.14	20.99
						Both	26.1	77.6		5.82	19.89
4		3.0	3.3 3.6 4.2	1.30	0.93	EL1	23.5	86.3	400	11.55	39.50
							21.9	87.9		11.81	40.40
							20.4	90.0		12.16	41.60
						EL2	21.9	85.8		12.66	43.30
							21.0	87.4		13.01	44.50
							19.4	90.1		13.25	45.30
	Both					37.3	77.6	10.67		36.50	
						36.4	80.8	11.17		38.20	
						35.3	85.8	11.61		39.70	
5	3.3	3.3	1.30	0.93	EL1	29.2	87.3	500	13.68	46.80	
					EL2	26.9	86.8		15.03	51.40	
					Both	44.2	78.2		12.66	43.30	

Note: 1. Lamp brightness and current draw can vary by type and manufacturer

HV839 External components used for Circuits 1 to 5

If other value inductors or the same value inductor with different series resistance are used, the circuit will need to be reoptimized by selecting proper R_{SW-OSC} . A smaller R_{SW-OSC} will need to be used for a same value inductor with a lower series resistance. Please refer to the Typical Application circuit on page 1 for the circuit diagram.

Circuit	R_{SW-OSC} (KΩ)	L_x Inductor		C_s Capacitor	
		Value (μH)	MuRata Part #	Value (nF)	Type
1	330	220	LQH32CN221K21	3.3	NPO
2	470	390	LQH32CN391K21	3.3	NPO
3	560	470	LQH32CN471K21	3.3	NPO
4	270	330	LQH32CN331K21	3.3	NPO
5	220	220	LQH32CN221K21	3.3	NPO

Supertex inc. does not recommend the use of its products in life support applications, and will not knowingly sell them for use in such applications unless it receives an adequate "product liability indemnification insurance agreement." Supertex inc. does not assume responsibility for use of devices described, and limits its liability to the replacement of the devices determined defective due to workmanship. No responsibility is assumed for possible omissions and inaccuracies. Circuitry and specifications are subject to change without notice. For the latest product specifications refer to the Supertex inc. website: <http://www.supertex.com>.