

# HV430, 105 V<sub>RMS</sub> Ring Generator

by Scott Lynch, Senior Applications Engineer

## Introduction

Telephones require at least 40VRMS for the proper detection of a ringing signal. Therefore, the ringing amplitude at the phone company must be high enough to account for voltage drops due to wire impedance and ringer load. Ringer load is measured in Ringer Equivalence Number (REN), with 1 REN representing a single ringer load of 7000Ω (6929Ω in series with 8.0μF). One phone line should be able to support up to 5 telephones, resulting in a total of 5 RENs per line.

The following graph shows the distances that can be achieved with various ring amplitudes and ring trip resistances. This graph assumes 26 AWG wire at 0.13Ω per meter. It is assumed that 500 meters of 26 AWG wiring (1000 meter loop) exists within the subscriber's premises. This wire length reflects the rule-of-thumb that the ringing signal should be at least 44V<sub>RMS</sub> at the subscriber's point of entry.

A current sense resistor (commonly referred to as a ring trip resistor) in series with the phone line is used to detect an off-hook condition during ringing. This resistor senses either a DC current flow or a high AC current. Note that using DC current to sense an off-hook condition requires a ringing waveform with a DC offset. Typically, this offset is the battery voltage of -48V. Typical values for ring trip range from 50 to 200Ω. Maximum distances decrease about 3.9 meters for every ohm of ring trip resistance.

As can be seen, the HV430 with its maximum sinusoidal amplitude of 105V<sub>RMS</sub> can achieve distances up to nearly 8km. Longer distances can be achieved using a trapezoidal ringing waveform.

This application note explains the operating principle behind the HV430 switchmode ring generator and provides many example circuits, including power supplies and PWM sinewave generators.

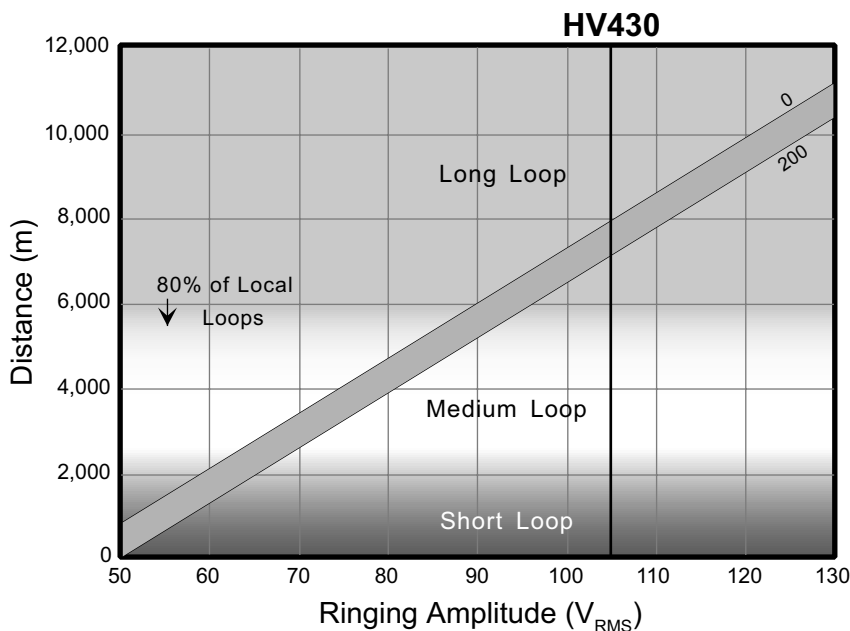

**Figure 1: Maximum Ring Generator-Subscriber Distances**

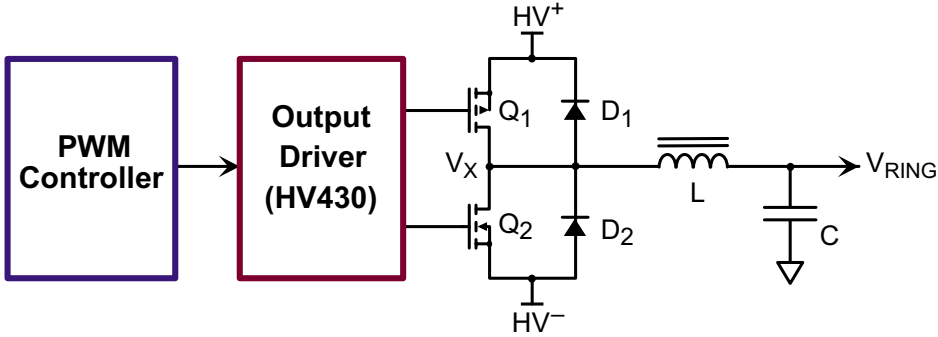

Figure 2: Basic Ringmode Ring Generator

Basic Switchmode Topology

Figure 2 depicts the basic topology of a switchmode ring generator. A microprocessor, ASIC, or analog circuitry serves as a PWM controller, which provides PWM signals to the output driver, which, in turn, provides voltage translation, transistor drive, current limiting, and several other functions.

This basic topology can be operated in one of two modes: continuous or discontinuous. In discontinuous mode, inductor current returns to zero between PWM cycles, while in continuous mode current is constantly circulating, even in the absence of a load. Continuous mode is essentially a Class D amplifier, while discontinuous mode is best thought of as two buck converters operating in parallel – one to source current and one to sink current. Figures 3 and 4 graphically show the difference between these two modes.

Continuous Mode

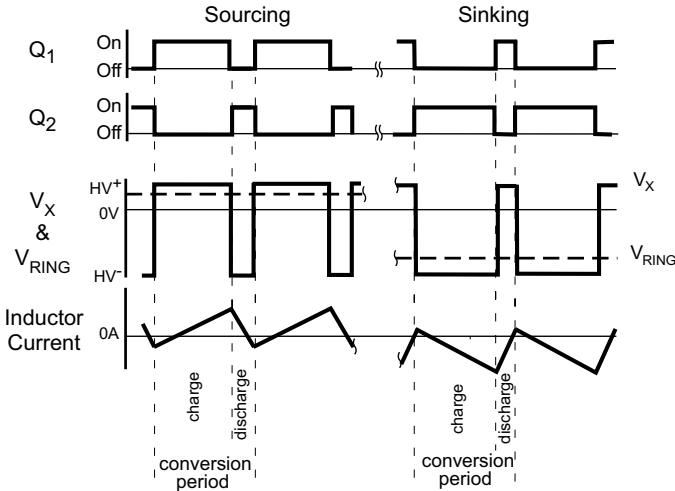

Figure 3: Continuous Mode Operation

In continuous mode, one of the two output transistors is always on, except for a small amount of deadband to prevent cross-conduction. This means the voltage waveform on the switching side of the inductor ( $V_x$ ) is at one high voltage supply or the other. The spectrum of  $V_x$  is composed of two groups of frequency components. One group is composed of the switching frequency and its harmonics, while the ringing frequency and its harmonics form the other group. In continuous mode, the inductor and capacitor function as a 2-pole low-pass filter, removing the switching frequency components but passing the ringing frequency and its harmonics. Neglecting loading effects, the instantaneous output voltage is simply the duty cycle average of the high voltage supplies.

The inductor value determines the output impedance of the ring generator. The lower the inductor value, the lower the output impedance and the better the load regulation. The penalty of lower inductor values is higher circulating currents. These higher currents require higher rated MOSFETs and rectifiers, and also result in less efficient operation as  $I^2R$  losses increase.

Deadband must be employed to prevent cross conduction in the output switches. This deadtime can be relatively generous, as the freewheeling rectifiers will conduct for a short amount of time before inductor current reverses and the transistor begins conducting.

With properly chosen components, open-loop load regulation can be held to a few percent. Closed loop operation improves load regulation and lowers THD, but requires more complex circuitry. Open loop operation is generally suitable for all applications.

Neglecting loading effects, the following equations define output voltage in terms of input duty cycle and supply voltages. The first equation is used to calculate instantaneous output voltage for a given duty cycle, while the other two define ringing signal parameters for a given set of input duty cycle parameters:

$$V_{out} = V_{NN} + D(V_{PP} - V_{NN})$$

$$V_{amp(P-P)} = (D_{max} - D_{min})(V_{PP} - V_{NN})$$

$$V_{offset} = V_{NN} + D_{avg}(V_{PP} - V_{NN})$$

where:

$V_{out}$  = instantaneous output voltage

$V_{NN}$  = negative high voltage supply

$V_{PP}$  = positive high voltage supply

$D$  = input duty cycle

$V_{amp(P-P)}$  = ringing signal amplitude in volts peak-to-peak

$V_{offset}$  = ringing signal DC offset

### Discontinuous Mode

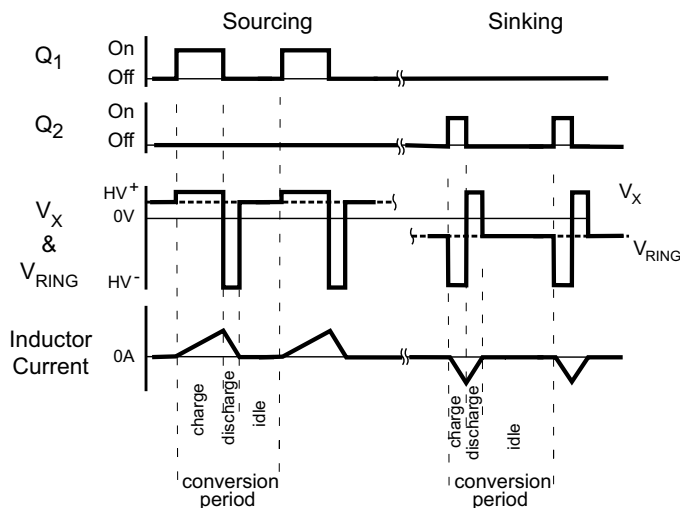

**Figure 4: Discontinuous Mode Operation**

As stated earlier, discontinuous mode is best thought of as two paralleled buck converters operating one at a time – one

to source current and one to sink current. A small deadband must be employed when the output switches from sourcing to sinking (and vice versa) to prevent both converters from operating simultaneously. This may result in a small amount of crossover distortion in the ringing signal.

Discontinuous mode works by controlling the amount of energy transferred to the output with each conversion cycle. Multiplying this energy by the conversion frequency yields the power delivered to the load. Raise the power and output voltage increases. Lower it and the output voltage decreases. For this scheme to work properly, feedback and control circuitry are required to determine the amount of energy transferred each cycle. For this reason, discontinuous mode is more complicated than continuous mode. There is an advantage, however. In continuous mode operation, currents are circulating even in the absence of a load, causing unnecessary power consumption. Discontinuous operation only entails currents proportional to the load, leading to higher efficiencies.

Each mode has its advantages and disadvantages. Continuous mode is simple and can operate open-loop, but currents will circulate even in the absence of a load. Discontinuous mode uses less current under no load conditions, but requires more complex circuitry. Either of these converters offers four quadrant operation with reverse energy transfer back to the high voltage supplies for reactive loads. Efficiencies of 80% to 90% are easily achievable.

When using the HV430, the MODE input must be set correctly depending on continuous/discontinuous mode. For independent control of the output N and P channel switches, the MODE input is set high. For continuous mode, the MODE input should be set low. The output is then controlled from the N<sub>IN</sub> input.

Programmable deadband (via the DEADBAND pin) assures break-before-make on the output switches, preventing cross conduction. Deadband can be somewhat generous, since the freewheeling diodes will conduct a certain amount of time before current in the inductor reverses and the MOSFET takes over.

## Kickback

One thing to be aware of when using this type of ring generator is kickback. Referring to Figure 5, kickback occurs during the discharge phase when inductor current is flowing thru the freewheeling rectifier. As can be seen, this current is being returned to the opposite supply. Since most power supplies are not designed to absorb power, this returned energy will charge the high voltage supply's output capacitor with each conversion cycle, causing supply voltage to rise. The voltage stops rising when the ringer output switches from sinking to sourcing (or vice versa) and energy is then being drawn rather than returned. Thus, kickback alternates between the two supplies at the ringing frequency. Without adequate high voltage output capacitors to absorb kickback, voltage could rise to destructive levels. Generally, about  $10\mu\text{F}$  per REN is adequate.

Note that because of kickback, only capacitively coupled loads may be driven. Light DC loads and transient heavier DC loads may be driven, however.

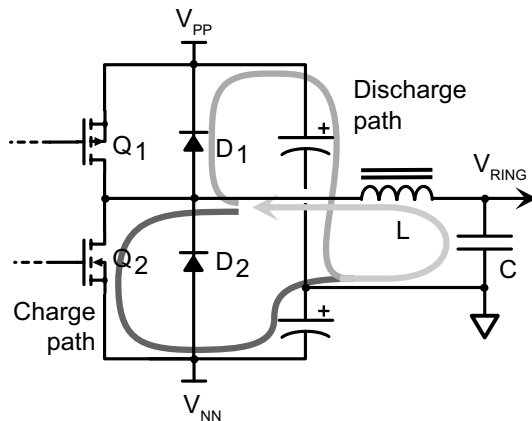

*Sinking load current shown.  
Sourcing current paths are the mirror image.*

**Figure 5: Kickback Current Paths**

## Ripple

ANSI T1.413 specifies the upstream channel for ADSL to be contained within a band from 25 to 138kHz. Typical ring generator PWM switching frequencies fall within this range, therefore careful attention must be exercised to prevent ring generator ripple from interfering with ADSL carriers. This is especially critical for the upstream carriers as they are attenuated by the time they reach the ring generator end of the line. Two means are available for mitigating this potential problem: minimizing ripple at the ring generator and attenuating residual ripple at the ADSL POTS splitter. Ripple may be reduced at the ring generator by increasing output capacitance or by the addition of a small LC filter.

## Overcurrent protection

Any ring generator should incorporate overcurrent protection. Overloads frequently occur when a subscriber picks up a ringing telephone. This off-hook condition may last 0.2 second until ring trip circuitry senses the off-hook condition and disconnects the off-hook load. During this time, the ring generator may see loads as low as  $200\Omega$ . Additionally, it is inevitable that phone lines will short on occasion.

Ideally, current limiting should occur prior to inductor saturation. Once the inductor saturates, current rises extremely quickly. This then requires a very fast overcurrent shutdown to prevent damage to the ring generator and other circuitry. It is far better to set the overcurrent limit below the inductor saturation point, even if this requires a slightly higher rated inductor.

For corrective action to be taken in the event of an overload condition on the line, the ring generator should flag an overcurrent condition to the host controller. This, in turn, can alert a technician to the problem. Otherwise, no one may know a problem exists and the subscriber may wonder why no phone calls have been received.

## Example Ring Generator

The schematic on the next page shows an HV430-based ring generator. In addition to the circuit depicted, 2 high voltage power supplies and a PWM controller are required. The PWM controller can be implemented as part of an ASIC or microcontroller, or can be implemented using an analog circuit (one possibility being shown later).

Keeping things simple, operation is in continuous mode, eliminating the need for complex feedback and control circuitry. Ringing amplitude and offset are determined by the voltages of the two high voltage supplies and by the duty cycles of the PWM input.

Cycle-by-cycle current limiting is provided by the Supertex HV430, with trip point determined by sense resistors R2 and R4. Filtering is required to prevent false triggering caused by turn-on spikes created by high currents resulting from discharging parasitic capacitances at the drains of the output transistors. To alert the host controller of an overcurrent condition, a de-glitched FAULT output is available. Deglitching prevents multiple interrupts and polling aliasing problems.

A power-on reset feature of the HV430 guarantees the driver outputs are in an off state upon initial application of power. This allows the host controller to come up to speed before

the ringer output is enabled. A 3.3μF capacitor from RESET to ground provides about 2 seconds of delay.

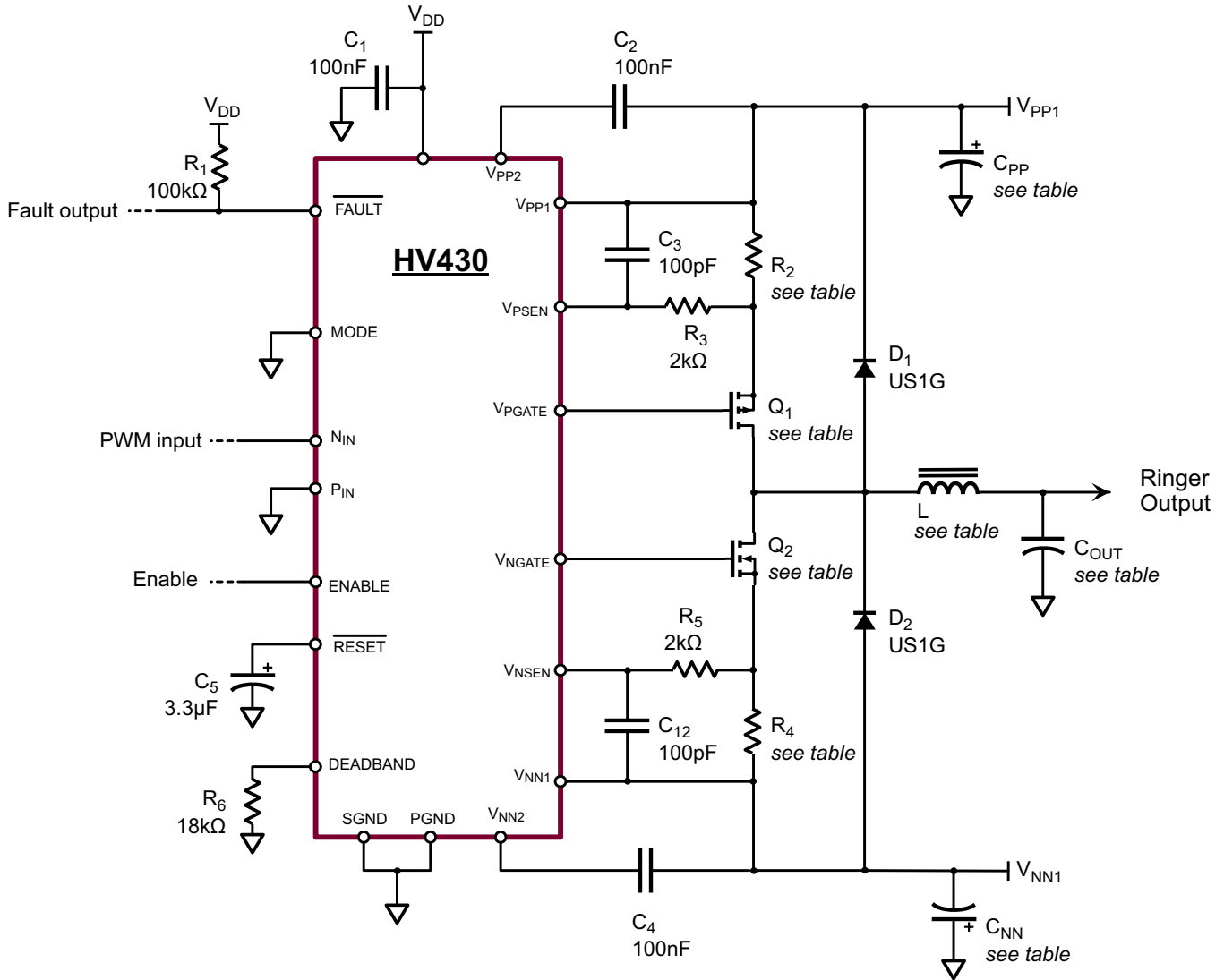

Figure 6: Generic HV430 Ring Generator

Component		5 REN	10 REN	20 REN	30 REN
R2 & R4 (Ω)		2.2	1.5	1.0	0.51
Q1		TP2540	TP2540	IRFR9310	IRFR9310
Q2		TN2540	TN2540	IRFR310	IRFR310
L	mH	15	8.2	4.7	3.3
	mA	120	230	440	670
C <sub>OUT</sub> * (nF)		150	270	470	680
C <sub>NN</sub> & C <sub>PP</sub> (μF)		47	100	200	330

\* Yields about 1V<sub>PP</sub> of ripple at 100kHz switching frequency

### High Voltage Power Supplies for a 5 REN Ring Generator

Inexpensive high voltage power supplies capable of supporting a 5 REN ring generator can be constructed using a simple 555 timer, off-the-shelf inductor, and a handful of other components. The circuit is a basic flyback boost converter using a 555 timer to provide a PWM signal to control switch QSW. By varying the duty cycle of the switch, output power can be controlled. Normally, timing components RC, RD, and CT determine frequency and duty cycle. In the positive supply, feedback resistor RFB and Zener ZFB add a positive bias to the timing circuit, with bias voltage increasing with increasing output voltage. This bias speeds up charging of

timing capacitor CT but slows down discharging, with the net result a decrease in duty cycle as output voltage increases. This mechanism provides the negative feedback necessary for regulation. The negative supply works in a similar fashion. With properly chosen components, this circuit regulates output voltage while maintaining switching frequency reasonably constant.

The supplies presented below are designed to operate from a -48V source. The positive high voltage supply outputs +100V, while the negative supply outputs -200V. These voltages were chosen to accommodate a typical -48V DC offset of the ringing signal.

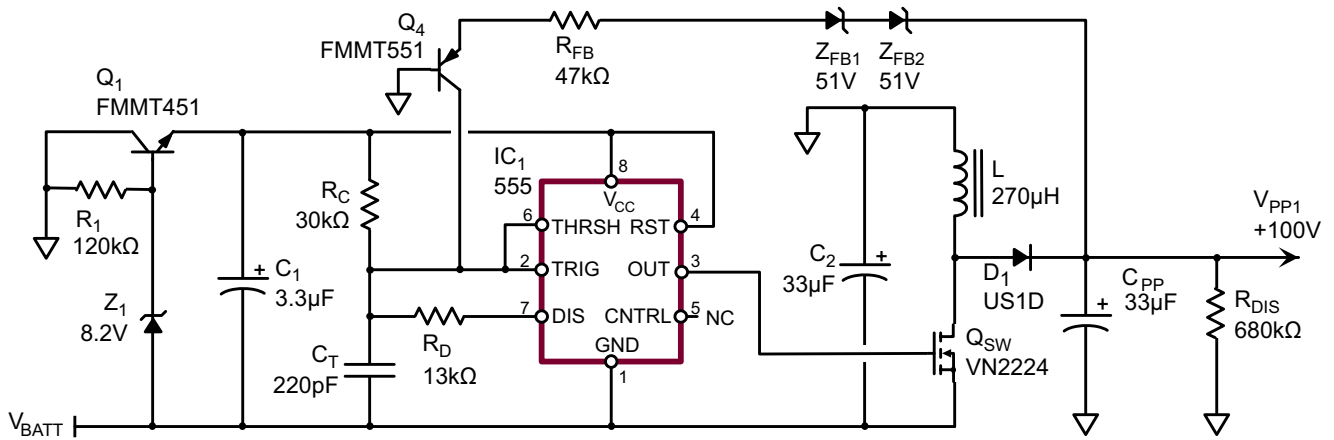

Figure 7: Positive Supply

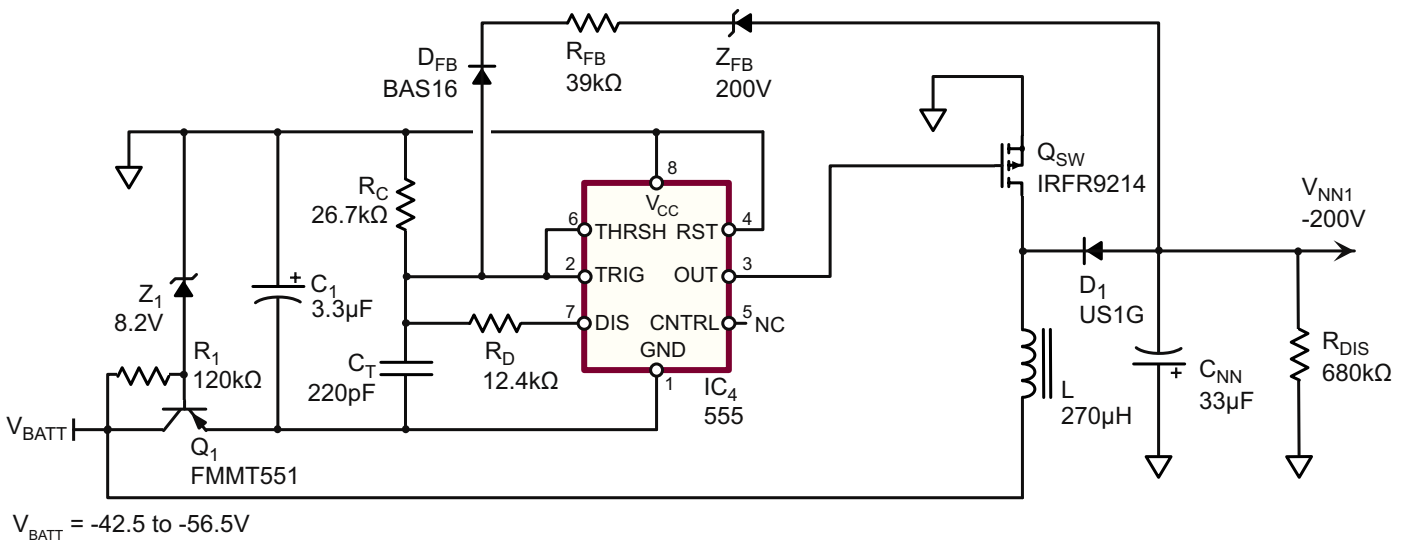

Figure 8: Negative Supply

## Inexpensive PWM Sinewave Generator

An inexpensive PWM sinewave generator can be constructed from a dual comparator IC and a handful of passive components, as shown below.

This circuit is designed to provide a PWM signal varying between 8% and 92% duty cycle that when reconstructed using a low pass filter (such as the LC filter of the ring generator), produces a 20Hz sinewave. Reconstructed sine

wave THD is about 3%. For lower distortion, a high speed comparator with a push-pull output may be used in place of the open-collector LM2903.

This circuit is sensitive to component tolerances, therefore 1% resistors must be used (1k $\Omega$  pull-ups excepted). Capacitors C3 and C4 should be 2%, while C1 and C2 may be 10% tolerance.

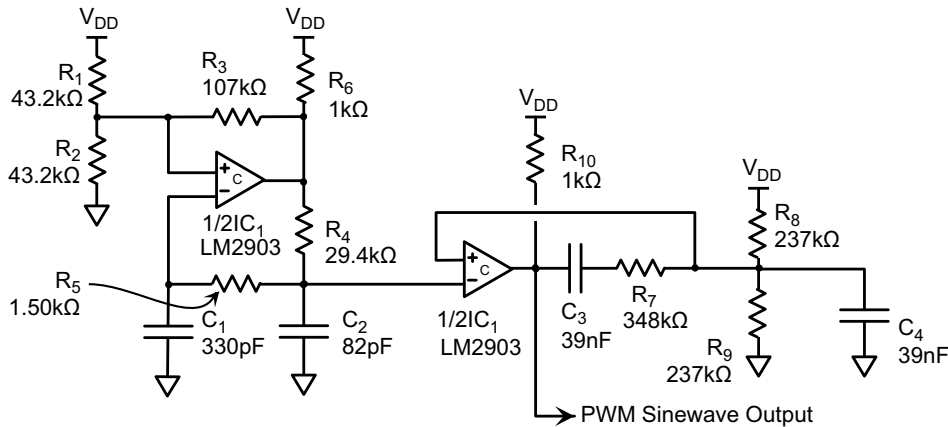

**Figure 9: PWM Sinewave Generator**

**Supertex inc.** does not recommend the use of its products in life support applications, and will not knowingly sell them for use in such applications unless it receives an adequate "product liability indemnification insurance agreement." **Supertex inc.** does not assume responsibility for use of devices described, and limits its liability to the replacement of the devices determined defective due to workmanship. No responsibility is assumed for possible omissions and inaccuracies. Circuitry and specifications are subject to change without notice. For the latest product specifications refer to the **Supertex inc.** website: <http://www.supertex.com>.