

## LR8/LR12: High Voltage Linear Regulators and Constant Current Sources

### General Description

The LR8/LR12 are high voltage 3-terminal adjustable linear regulators. Intended for operation directly off rectified AC mains, the LR8 operates at input voltages up to 450V, making it compatible with line voltages up to 230VAC. The

LR12, with its 100V maximum input, is ideal for 48V telecom applications. Their output voltage adjustability assures that they can be used in most any application.

Relevant specifications are shown in the table below:

Parameter	LR8	LR12
Input Voltage Range	$(V_{OUT} + 12V)$ to 450V	$(V_{OUT} + 12V)$ to 100V
Output Voltage Range	1.2V to $(V_{IN} - 12V)$	1.2V to $(V_{IN} - 12V)$
Output Voltage Accuracy	±5%	±5%

### Power Dissipation (@ 25°C T<sub>AMB</sub>)

TO-92:	0.6W	0.6W
TO-243AA:	1.3W	—
SO-8:	—	1.8W
TO-252 (D-PAK):	2.0W	2.0W
Output Current	0.5 to 10mA	0.5 to 50mA
Load Regulation	3%	3%
Line Regulation	0.01%/V	0.01%/V
Supply Rejection	60dB typ @120Hz	60dB typ @120Hz
Minimum C <sub>OUT</sub>	1µF	100nF

### LR8/LR12 Block Diagram and Typical Application

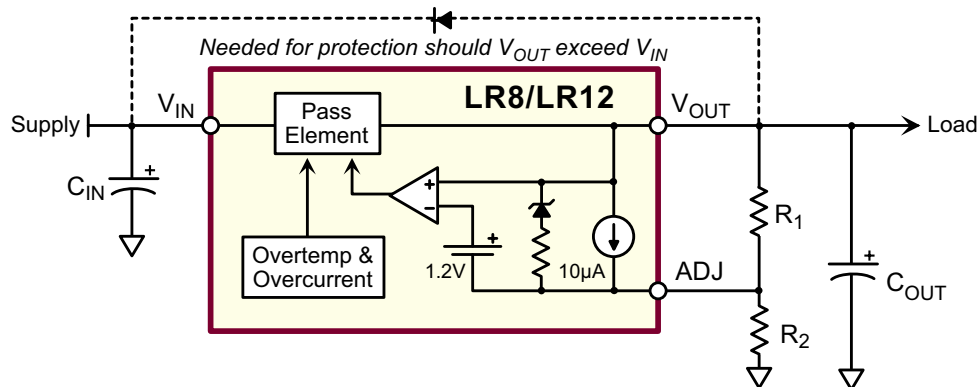

$$V_{OUT} = 1.2V \left( 1 + \frac{R_2}{R_1} \right) + 10\mu A \cdot R_2$$

## Operation

Except for their higher voltage rating, the LR8/LR12 operate like any other 3-terminal adjustable linear regulator.

A simple resistive divider sets the output voltage while a capacitor at the output improves transient response and ensures regulator stability. When applicable, an input capacitor is required to provide energy storage for rectified AC.

Keeping in mind that the LR8/LR12 require at least a 12V difference between input and output for proper operation, the minimum value for  $C_{IN}$  is:

$$C_{IN} > I_{LOAD} \frac{t}{V_{IN(pk)} - V_{OUT} - 12V}$$

where:

- $I_{LOAD}$  = Load current
- $t$  = Time between peaks of input waveform
- $V_{IN(pk)}$  = Peak input voltage
- $V_{OUT}$  = Output voltage

Note that the LR8/LR12 require a minimum of 0.5mA load current for proper operation. The current through the resistive divider may be included as part of the minimum load.

## Constant Current Operation

The LR8/LR12 may be configured to provide a constant current output. The current is independent of both supply voltage and load impedance. Constant current operation finds application in driving LEDs and trickle-charging NiCad batteries, as shown below. The trickle charger is for applications that require battery backup (i.e. no cycling), such as emergency lights.

## Constant Current LED Driver

$$I_{LED} = \frac{1.2V}{R}$$

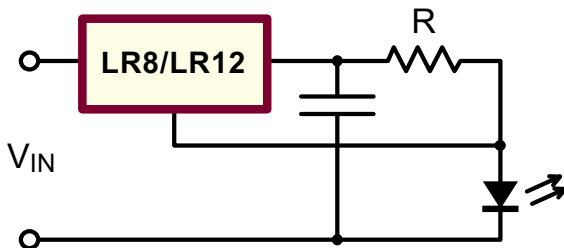

## NiCad Battery Trickle Charger

$$I_{CHG} = \frac{1.2V}{R}$$

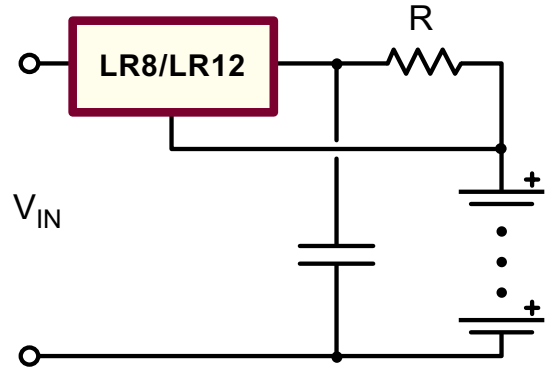

## Start-up Circuit

The schematic below depicts a simplified off-line switching power supply using the LR8 for start-up. A similar circuit may be used for the LR12 for input voltages of less than 100V. When  $V_{BOOT}$  rises above the LR8's output voltage, the LR8 goes into standby mode, consuming very little current. All current is then supplied from the bootstrap circuit rather than from the high voltage source, increasing overall efficiency.

The output voltage of the LR8 should be set high enough above the minimum operating voltage of the PWM controller, yet low enough to ensure the bootstrap circuit takes over after start-up.

With 230VAC input, instantaneous power dissipation can reach 3.25W ( $325V_{PK} \cdot 10mA$ ). This level exceeds the LR8's rating, but exists for only as long as it takes for the supply to bootstrap. Thermal mass will prevent the die temperature from rising quickly. If boot time is short, die temperatures will not reach the overtemperature protection trip point. It is advisable to mount the LR8 on 2 oz. copper with an area of at least 2.5 square centimeters.



1. Input voltage is applied. The LR8/LR12 begins operating (in current limiting mode since  $C_{OUT}$  appears as a short).  $V_{OUT}$  begins to rise as  $C_{OUT}$  charges. The PWM controller draws a small amount of current.
2. The output voltage of the LR8/LR12 reach the PWM controller's turn-on threshold. Controller begins operating, drawing current. Bootstrap voltage begins climbing while  $V_{OUT}$  decays since current drawn by the controller exceeds the LR8/LR12's current limit.
3. Bootstrap voltage reaches the level of the LR8/LR12's output and takes over. LR8/LR12 currents drop to zero.
4. Power supply reaches steady-state operation.

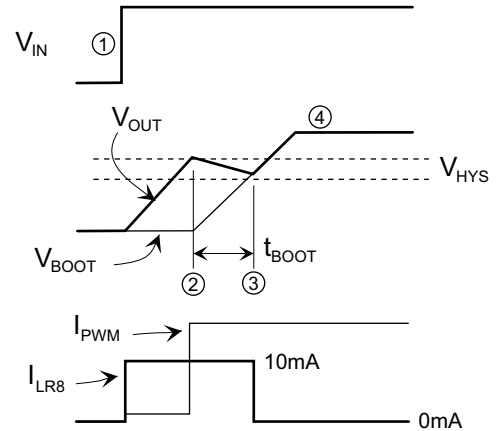

The minimum capacitance required for given boot-up time is given by the following equation:

$$C_{OUT} > t_{BOOT} \frac{I_{PWM} - I_{LIM}}{V_{HYS}}$$

where:

- $C_{OUT}$  = Capacitor at LR8/LR12 output
- $t_{BOOT}$  = Time required for supply to bootstrap
- $I_{PWM}$  = Current used by PWM controller
- $I_{LIM}$  = LR8/LR12 current limit (LR8: 10mA, LR12: 50mA)
- $V_{HYS}$  = PWM controller UVL hysteresis

Remember that this equation is valid only when PWM currents exceed the LR8/LR12's current limit.

## Calculating Maximum Output Current

The LR8/LR12 have built-in current limiting, however, power dissipation may limit maximum continuous current to less than the built-in current limit. Power dissipation is given by:

$$P_{LR} = I_{OUT} (V_{IN} - V_{OUT})$$

This power dissipation will cause die temperature to rise above ambient ( $T_{amb}$ ), the amount determined by the thermal resistance from junction to ambient ( $\theta_{ja}$ ). Since the LR8/LR12 have overtemperature protection that kicks-in as low as 125°C, junction temperature cannot exceed this amount.

$$\begin{aligned} T_j &= T_{amb} + \theta_{ja} P_{LR} \\ &= T_{amb} + \theta_{ja} \cdot I_{OUT} (V_{IN} - V_{OUT}) \end{aligned}$$

Rearranging the above equation yields a convenient equation that specifies maximum output current for given operating conditions. Remember that the output current cannot exceed built-in current limiting (10mA for LR8, 50mA for LR12).

$$I_{OUT(MAX)} = \frac{T_{j(MAX)} - T_{amb}}{\theta_{ja} (V_{IN} - V_{OUT})}$$

where  $T_{j(MAX)} = 125^\circ\text{C}$

If the maximum possible output current does not meet requirements, thermal resistance may be lowered by increasing the copper area used as a heat sink. In addition, a copper area on the other side of the PCB may be employed, connected by thermal vias.

As an example, the following graph shows the current capabilities of the LR8/LR12 at 25°C ambient with a 25mm x 25mm single-sided copper area heat sink for the surface mount devices and a  $V_{OUT}$  of 5.0V.

## LR8/LR12 Current Capability

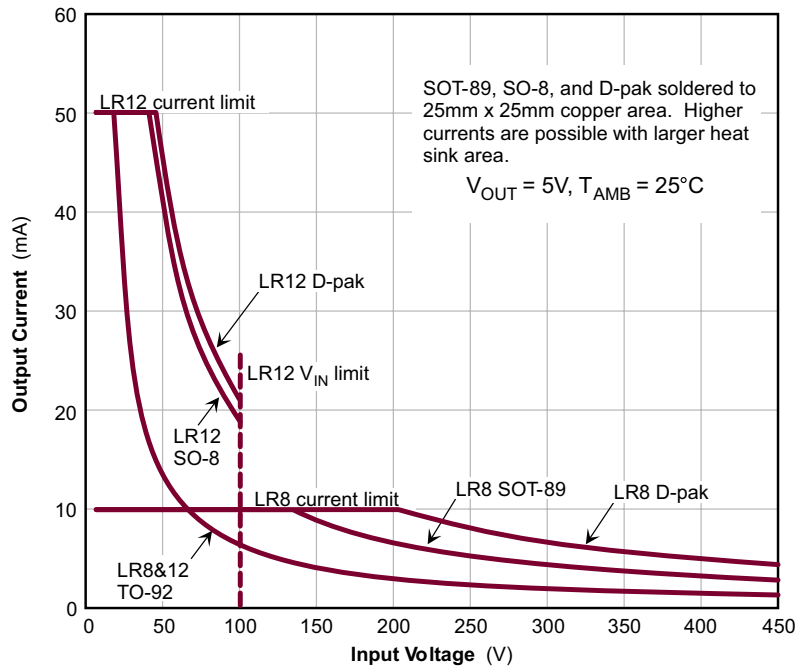

## Thermal Resistance

Package	$\theta_{jc}$ ( $^{\circ}C/W$ )	$\theta_{ja}$ ( $^{\circ}C/W$ )
TO-92	125	170
SOT-89	15	78
SO-8	-	55
D-PAK	6.25	50

\* When mounted to 25mm x 25mm copper area

Supertex inc. does not recommend the use of its products in life support applications, and will not knowingly sell them for use in such applications unless it receives an adequate "product liability indemnification insurance agreement." Supertex inc. does not assume responsibility for use of devices described, and limits its liability to the replacement of the devices determined defective due to workmanship. No responsibility is assumed for possible omissions and inaccuracies. Circuitry and specifications are subject to change without notice. For the latest product specifications refer to the Supertex inc. website: <http://www.supertex.com>.