

HT0638 Electronic Line Switch

by Scott Lynch, Senior Applications Engineer

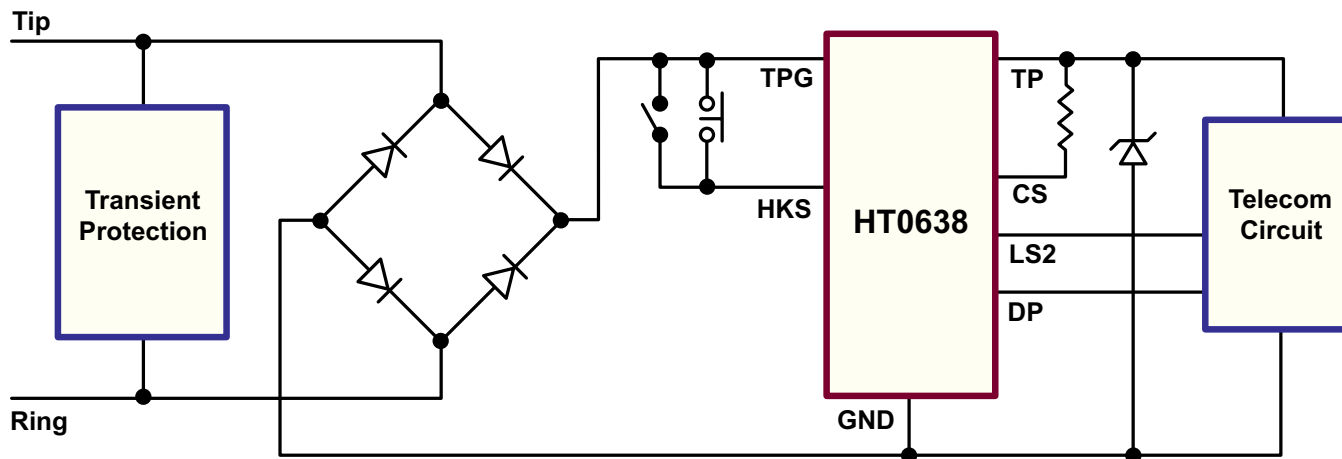

Figure 1: Integrated HT0638 Electronic Line Switch

Introduction

The Supertex HT0638 is an electronic line switch in an SO-8 package and is designed as a replacement for the typical mechanical hook switch in telephone instruments. It connects the telephone's low voltage speech and dialing circuits to the incoming phone line when the handset is placed off-hook. The HT0638 performs this function via a solid state switch, thereby eliminating any reliability problems commonly associated with mechanical switches. Four low-level hookswitch control inputs are provided for design versatility and may be controlled directly from logic circuitry or from ordinary mechanical switches. The HT0638 is line-powered and is especially useful in applications that require telephone operability when external power is lost or otherwise unavailable.

A solid state hook switch may be implemented in one of two ways: using discrete components or using the HT0638 integrated circuit. The discrete approach requires more components and board real estate compared to the integrated approach.

A typical application circuit using the HT0638 is shown in Figure 1

HT0638 Circuit Description

Figure 2 shows a block diagram of the HT0638 line switch. Four control inputs are provided: HKS, LS1, LS2, and DP. Internal pull-downs are provided for HKS, LS1, and LS2, while the DP input has an internal pull-up. All of these inputs may be driven from single-ended sources, from push-pull sources, or left unconnected.

An inexpensive mechanical switch or magnetic reed switch is placed across TPG and HKS of the HT0638. This switch is used solely to detect hook status and is not subject to the line currents of a conventional hook switch. (The hook status switch will be referred to as the hook switch. The solid state switch used to connect the instrument to the phone line will be referred to as the line switch.) With the handset in the on-hook condition, the hook switch is open. When the handset goes off-hook, the hook switch closes, allowing microamperes of current to flow into the HKS pin. This current activates an internal charge pump power supply which is used to turn on the internal 15Ω MOSFET line switch, connecting TPG to TP. An external Zener diode is recommended to clamp the voltage on the TP pin to the desired value. Under a fault condition where the Zener diode is not connected, the TP pin is internally limited to a nominal value of 18V.

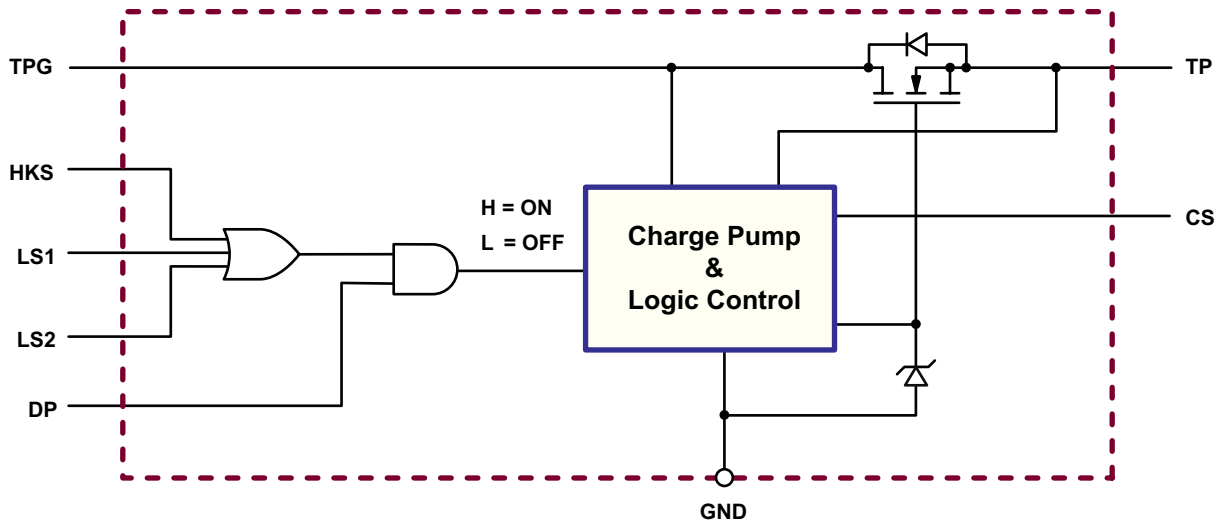

Figure 2: HT0638 Block Diagram

For a hands-free speaker function, a push-on/push-off button switch can be connected across the TPG and LS1 pins. This switch can be used to turn on the internal MOSFET line switch without lifting the handset. Alternatively, this input can be driven from logic circuitry to implement the hands-free function.

Other control inputs of the HT0638 are the LS2, DP, and CS pins. The LS2 can be used to place the instrument in a hold condition. The DP pin is used for pulse dialing.

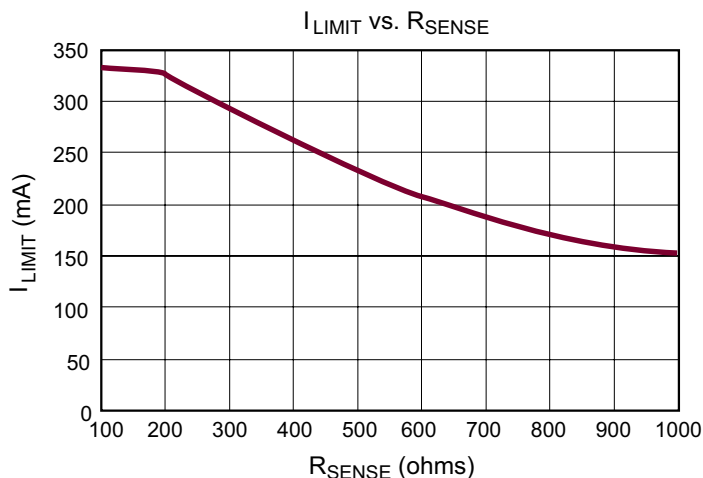

Figure 3: I_{LIMIT} vs. R_{SENSE}

Current Limiting

The CS pin is used for setting the current limit value. An external current resistor is connected between TP and CS. The

CS pin senses a small fraction of the current flowing through the internal MOSFET line switch. Figure 3 graphs the relationship between R_{SENSE} and current limit.

HT0638 Parameters

In this section, the importance of the primary electrical parameters of the HT0638 and how they relate to the application are explained. The primary requirements for an electronic line switch for a handset are:

- ▶ High breakdown voltage
- ▶ Low leakage current
- ▶ Low switch resistance
- ▶ Low operating voltage
- ▶ T_{ON}/T_{OFF} switching time

Breakdown Voltage

The internal MOSFET line switch shown in Figure 3 must be able to withstand high voltages which come from ring voltages and residual voltages from lightning strikes. Ring voltages as high as 300V_{PP} superimposed on a DC offset of -52.5V can result in peak voltages just over 200V. The HT0638's 375V rating provides an ample safety margin.

It is quite common for phone lines to encounter lightning surges. Even with proper lightning protection devices, voltage transients of 350V can be encountered. The 375V breakdown rating for the HT0638 provides adequate protection.

Low Leakage

Regulations require that devices connected to the public switched telephone network (PSTN) present an on-hook resistance greater than 5.0MΩ up to 100V. Lower resistances may give a false indication that the line is damaged. The HT0638 is rated for 2.0μA max at 100V, equating to 50MΩ. Under low voltage conditions of 42.5V, the 2.0μA rating equates to 21.25MΩ, well within the requirements.

Switch Resistance

The amount of current flowing into the instrument will depend on how far it is from the central office. Currents can vary from 5.0mA to 140mA. The switch resistance is important in both cases. For the high current condition where the instrument is close to the central office, the switch resistance should be kept low to minimize power dissipation. The HT0638 is rated as 15Ω.

The power dissipation is therefore:

$$(140mA)^2 \cdot 15\Omega = 294mW$$

For the long loop condition, low current, 20mA is available. The phone needs to be fully functional under this condition. The amount of voltage available during this condition is 3.0V. The HT0638 guarantees a switch resistance of 15Ω when conducting 20mA with an input voltage of only 3.0V, resulting in a drop across the line switch of only 0.3V.

Low Operating Voltage

Consider a long loop condition where the phone is off-hook. 20mA will be flowing to the phone. A common situation would be for a second phone on the same line to go off-hook where the second user is not aware that the phone line is in use. More current will be drawn from the line and voltage will be further reduced. Under this condition, it is not necessary for the phones to be fully functional. It is, however, required that the speech circuitry be functional on both phones. This will allow the first user to inform the second user that the line is in use and to go on hook.

Further compounding the condition would be if one of the phones was old. The old phone would draw more current to maintain speech functionality. To provide more current for the old phone, the HT0638 must operate under very low current and voltage conditions. The HT0638 might draw only 5mA whereas the old phone will consume 20mA. The HT0638 therefore guarantees a maximum of 30Ω switch resistance at 5.0mA with an input voltage of 2.0V.

Summarizing the switch resistance and operating voltage requirements:

Condition	Current (mA)	Voltage (V)	Switch Resistance (Ω)
Short Loop	130	4.3	15
Long Loop	20	3.0	15
Long Loop with 2 Phones	5.0	2.0	30

Ton/Toff Switching Time

The HT0638 has a DP pin which can be used for pulse dialing. The DP input is internally pulled up and may be driven from a push-pull source or from an open-drain source. Pulse dialing requires 40ms on time and 60ms off time. For proper pulse dialing recognition, T_{ON} and T_{OFF} must be less than 2.0ms. The HT0638 guarantees a T_{ON} and T_{OFF} of no greater than 1.0ms, well within the requirements.

Conclusion

The HT0638 is specifically designed to replace the mechanical hook switch in telephone handset applications. The strict electrical requirements imposed on telephone instruments has been taken into consideration. Designs currently incorporating a discrete electronic line switch will also benefit from the simplification and component reduction when re-designed for the HT0638. The HT0638 will allow for a more reliable, higher performance and more compact solution.

Supertex inc. does not recommend the use of its products in life support applications, and will not knowingly sell them for use in such applications unless it receives an adequate "product liability indemnification insurance agreement." Supertex inc. does not assume responsibility for use of devices described, and limits its liability to the replacement of the devices determined defective due to workmanship. No responsibility is assumed for possible omissions and inaccuracies. Circuitry and specifications are subject to change without notice. For the latest product specifications refer to the Supertex inc. website: <http://www.supertex.com>.